

# Digilent Pmod REG1™ Voltage Regulator Module Reference Manual

Revision: November 06, 2006



215 E Main Suite D | Pullman, WA 99163  
(509) 334 6306 Voice and Fax

## Overview

The Digilent PmodREG1 is a small form factor voltage regulator able to provide up to 250mA of current at 3.3V. It is specifically designed to work with the Digilent Pmod modules and small embedded control boards, such as the Nanocon, ServoMini, or PmodSF, but is also useable as a general-purpose voltage power supply module.

Features include:

- 250mA low dropout linear regulator
- fixed 3.3V output voltage
- input voltage range of 3.8V-16V
- small form factor (0.80" x 1.20").

## Functional Description

The PmodREG1 is intended to provide power to Digilent Pmod peripheral modules when they are being used for stand-alone operation not connected to a Digilent system board, or as the power supply for small embedded control modules, such as the Nanocon, that do not have an integral power supply.

The Digilent Pmod modules use a six-wire interface made up of four data signals, power, and ground. The PmodREG1 is designed to function as a pass-through module that will pass the four data signals through itself and provide power on the power and ground pins.

The input voltage to the regulator is connected via screw terminal connector J3. Any voltage source between 3.8V and 16V can be connected here. Observe proper polarity when connecting the input voltage source to J3. Digilent has available a coax power jack with pigtail wires that is suited for connecting a normal Digilent switching power supply to the PmodREG1 for operation from power mains.

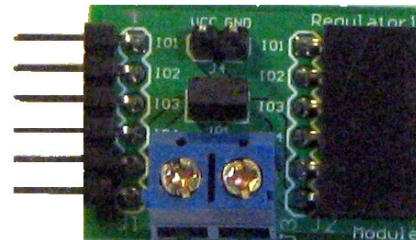

**Figure 1**  
**Digilent PmodREG1**

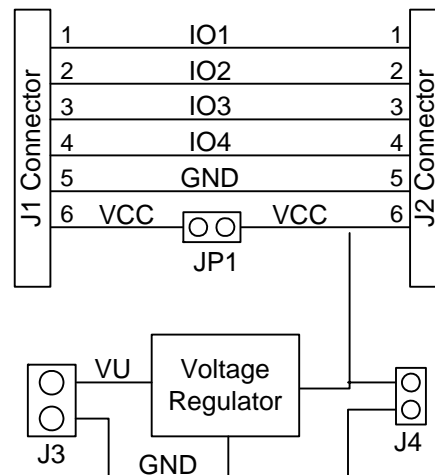

**Figure 2**  
**Block Diagram**

Alternatively, battery packs, also available from Digilent, can be attached to provide the input voltage source.

The output voltage from the regulator will appear on pin six of connector J2 and on the VCC pin of the 2-pin header J4. Jumper block JP1 controls whether the output voltage also appears on pin six of connector J1. If a shorting block is installed on JP1, the regulator output is connected to J1 too. To disconnect

the regulator output from J1, remove the shorting block on JP1.

The 2-pin header, J4, can be used to take power from the PmodREG1 module to power another device via a two-wire MTE cable. Many Digilent embedded control boards and Pmod module boards are equipped with a two-pin connector as an optional way to provide power to the board.