

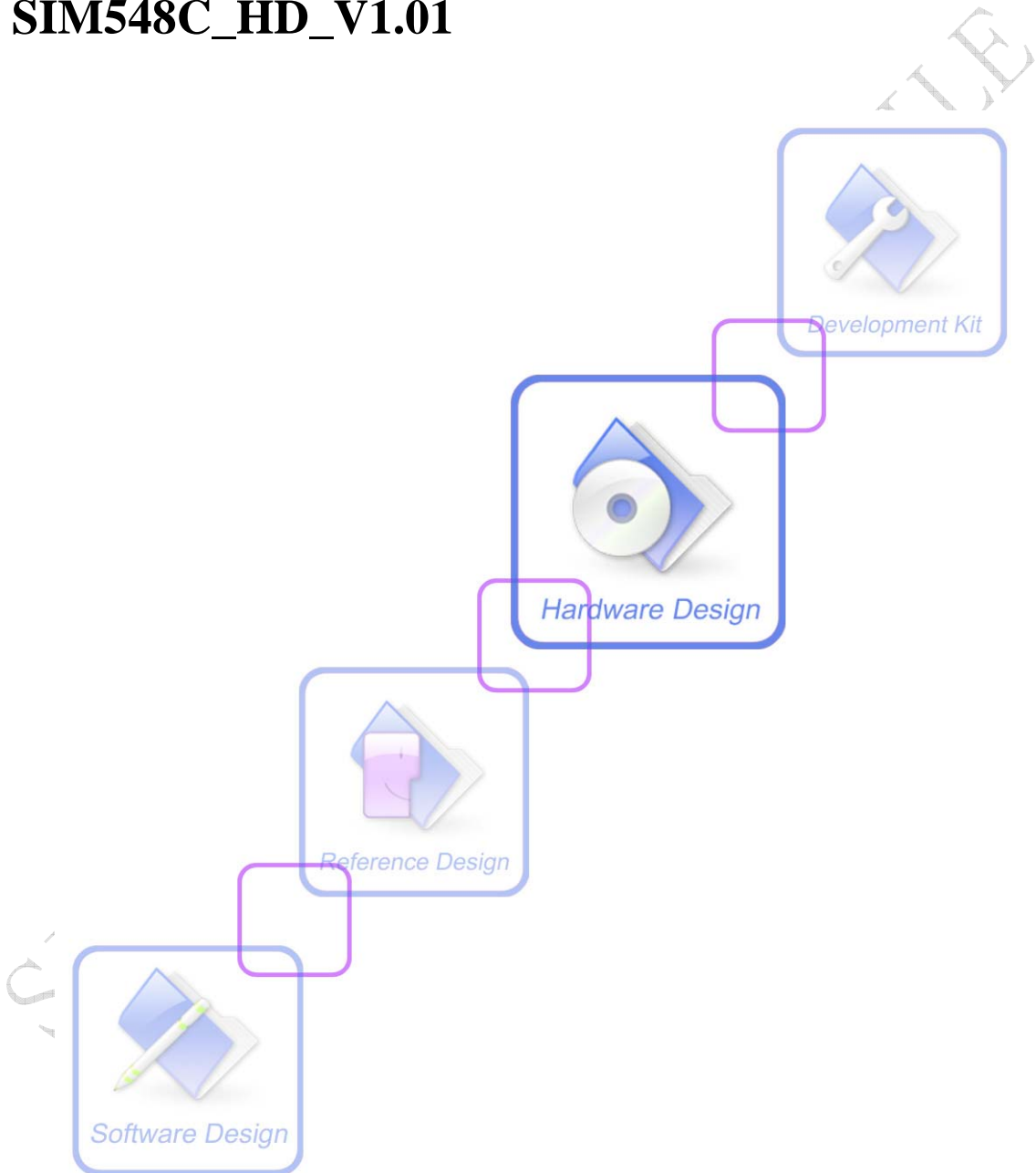

Hardware Design

SIM548C_HD_V1.01



Document Title:	SIM548C Hardware Design
Version:	1.01
Date:	2008-05-09
Status:	Release
Document Control ID:	SIM548C_HD_V1.01

General Notes

SIMCom offers this information as a service to its customers, to support application and engineering efforts that use the products designed by SIMCom. The information provided is based upon requirements specifically provided to SIMCom by the customers. SIMCom has not undertaken any independent search for additional relevant information, including any information that may be in the customer's possession. Furthermore, system validation of this product designed by SIMCom within a larger electronic system remains the responsibility of the customer or the customer's system integrator. All specifications supplied herein are subject to change.

Copyright

This document contains proprietary technical information which is the property of SIMCom Limited., copying of this document and giving it to others and the using or communication of the contents thereof, are forbidden without express authority. Offenders are liable to the payment of damages. All rights reserved in the event of grant of a patent or the registration of a utility model or design. All specification supplied herein are subject to change without notice at any time.

Copyright © Shanghai SIMCom Wireless Solutions Ltd. 2008

Contents

Contents	3
Version History	9
Scope of the document	9
1 Introduction	10
1.1 Related documents	10
1.2 Terms and abbreviations	11
2 Overview	14
2.1 Key features	15
2.2 Functional diagram	17
2.3 Evaluation board	18
3 GSM application interface	19
3.1 Pin description	19
3.2 Operating modes	21
3.3 Power supply	23
3.3.1 Power supply pins on the board-to-board connector	25
3.3.2 Minimizing power losses	25
3.3.3 Monitoring power supply	25
3.4 Power up and down scenarios	25
3.4.1 Turn on the GSM part	25
3.4.2 Turn off the GSM part	29
3.4.3 Restart the GSM part using the PWRKEY pin	32
3.5 Charging interface	32
3.5.1 Battery pack characteristics	33
3.5.2 Recommended battery pack	34
3.5.3 Implemented charging technique	35
3.5.4 Operating modes during charging	36
3.5.5 Charger requirements	38
3.6 Power saving	38
3.6.1 Minimum functionality mode	38
3.6.2 SLEEP mode (slow clock mode)	39
3.6.3 Wake up the GSM part from SLEEP mode	39
3.7 Summary of state transitions (except SLEEP mode)	40
3.8 RTC backup	41
3.9 GSM Serial interface	44
3.9.1 Function of serial port & debug port supporting	46
3.9.2 Software upgrade and software debug	47
3.10 Audio interfaces	49
3.10.1 Speaker interface configuration	50
3.10.2 Microphone interfaces configuration	51
3.10.3 Earphone interface configuration	52
3.10.4 Referenced electronic characteristic	52

3.11 SIM interface.....	53
3.11.1 SIM card application	53
3.11.2 Design considerations for SIM card holder	55
3.12 LCD interface.....	57
3.13 ADC	58
3.14 General purpose input & output(GPIO)	58
3.15 Behaviors of the RI line (serial port1 interface only).....	58
3.16 Network status indication.....	60
3.17 Buzzer	60
4 GPS application interface.....	62
4.1 Theory of operation.....	62
4.2 Technical data.....	63
4.3 Pin description.....	64
4.4 Turn on the GPS part.....	66
4.5 The theory of the GPS RTC circuit	67
4.6 The theory of the RESET Circuit	68
4.7 GPS operation modes	69
4.8 Serial interface of the GPS part.....	69
4.9 Start-up procedure.....	70
4.9.1 Coldstart	70
4.9.2 Warmstart	70
4.9.3 Hotstart	71
5 Antenna interface	72
5.1 GSM Antenna.....	72
5.1.1 GSM Antenna connector.....	72
5.1.2 GSM Antenna pad.....	72
5.1.3 Module RF output power.....	74
5.1.4 Module RF receive sensitivity.....	74
5.1.5 Module operating frequencies	74
5.2 GPS Antenna	74
5.2.1 GPS Antenna Connection.....	74
5.2.2 GPS Antenna Choice Consideration	75
6 Electrical, reliability and radio characteristics	77
6.1 Absolute maximum ratings.....	77
6.2 Operating temperatures	77
6.3 Power supply rating.....	78
6.4 Current consumption.....	79
6.4.1 The current consumption of the GSM part.....	79
6.4.2 The current consumption of the GPS part	80
6.5 Electrostatic discharge.....	83
7 Mechanics	85
7.1 Mechanical dimensions.....	85
7.2 Mounting the module onto the application platform.....	86
7.3 Board-to-board connector	86

SIM548C Hardware Design

7.3.1 Mechanical dimensions of the ASTRON 1590060-09T-R.....	87
7.3.2 Adapter cabling	88
APPENDIX A: PIN assignment of board-to-board connector.....	89
APPENDIX B: Reference Circuit with external MCU (GPS standalone application)	91
APPENDIX C: Reference Diagram with external MCU (AGPS application).....	92

SIMCOM CONFIDENTIAL FILE

Table Index

TABLE 1: RELATED DOCUMENTS	10
TABLE 2: TERMS AND ABBREVIATIONS	11
TABLE 3: KEY FEATURES.....	15
TABLE 4: CODING SCHEMES AND MAXIMUM NET DATA RATES OVER AIR INTERFACE..	17
TABLE 5: BOARD-TO-BOARD CONNECTOR PIN DESCRIPTION	19
TABLE 6: OVERVIEW OF OPERATING MODES.....	22
TABLE 7: AT COMMANDS USED IN ALARM MODE	29
TABLE 8: RECOMMENDED BATTERY PROTECT CIRCUIT PARAMETER.....	34
TABLE 9: SPEC OF RECOMMENDED BATTERY PACK	34
TABLE 10: OPERATING MODES	37
TABLE 11: AT COMMAND USUALLY USED IN GHOST MODE	37
TABLE 12: SUMMARY OF STATE TRANSITIONS.....	40
TABLE 13: PIN DEFINITION OF THE SERIAL INTERFACES	44
TABLE 14: LOGIC LEVELS OF SERIAL PORTS PINS	45
TABLE 15: PIN DEFINITION OF THE AUDIO INTERFACE.....	49
TABLE 16: MIC INPUT CHARACTERISTICS	52
TABLE 17: SPK OUTPUT CHARACTERISTICS	52
TABLE 18: PIN DEFINITION OF SIM INTERFACE (BOARD-TO-BOARD CONNECTOR)	54
TABLE 19: PIN DEFINITION (AMPHENOL SIM CARD HOLDER).....	56
TABLE 20: PIN DEFINITION (MOLEX SIM CARD HOLDER).....	57
TABLE 21: PIN DEFINITION OF THE LCD INTERFACE	57
TABLE 22: ADC SPECIFICATION	58
TABLE 23: PIN DESCRIPTION OF THE GPIO INTERFACE.....	58
TABLE 24: BEHAVIOURS OF THE RI LINE.....	58
TABLE 25: WORKING STATE OF THE NETLIGHT	60
TABLE 26: BUZZER OUTPUT CHARACTERISTICS	61
TABLE 27: PIN DEFINITION	64
TABLE 28: CONSOLIDATED PIN CHARACTERISTICS.....	66
TABLE 29: GPS OPERATION MODES	69
TABLE 30: THE GSM PART CONDUCTED RF OUTPUT POWER.....	74
TABLE 31: CONDUCTED RF RECEIVE SENSITIVITY OF THE GSM PART	74
TABLE 32: THE GSM PART OPERATING FREQUENCIES.....	74
TABLE 33: ABSOLUTE MAXIMUM RATINGS (GSM PART).....	77
TABLE 34: ABSOLUTE MAXIMUM RATINGS (GPS PART)	77
TABLE 35: OPERATING TEMPERATURE.....	78
TABLE 36: POWER SUPPLY RATING (GSM PART).....	78
TABLE 37: POWER SUPPLY RATING (GPS PART)	79
TABLE 38: CURRENT CONSUMPTION (GSM PART)	79
TABLE 39: THE ESD ENDURE STATUE MEASURED TABLE (TEMPERATURE: 25°C, HUMIDITY: 45%).....	84
TABLE 40: PIN ASSIGNMENT.....	89

Figure Index

FIGURE 1: FUNCTIONAL DIAGRAM	18
FIGURE 2: REFERENCE CIRCUIT OF THE VBAT INPUT	23
FIGURE 3: REFERENCE CIRCUIT OF THE SOURCE POWER SUPPLY INPUT	24
FIGURE 4: VBAT VOLTAGE DROP DURING TRANSMIT BURST	24
FIGURE 5: TURN ON GSM PART USING DRIVING CIRCUIT	26
FIGURE 6: TURN ON GSM PART USING BUTTON	26
FIGURE 7: TIMING OF TURN ON GSM PART	27
FIGURE 8: TIMING OF TURN OFF GSM PART	30
FIGURE 9: TIMING OF RESTART GSM PART	32
FIGURE 10: BATTERY CHARGER AND PACK	33
FIGURE 11: RTC SUPPLY FROM NON-CHARGEABLE BATTERY	41
FIGURE 12: RTC SUPPLY FROM RECHARGEABLE BATTERY	42
FIGURE 13: RTC SUPPLY FROM CAPACITOR	42
FIGURE 14: PANASONIC EECEMOE204A CHARGE CHARACTERISTIC	43
FIGURE 15: MAXELL TC614 CHARGE CHARACTERISTIC	43
FIGURE 16: SEIKO TS621 CHARGE CHARACTERISTIC	44
FIGURE 17: CONNECTION OF THE SERIAL INTERFACES	46
FIGURE 18: CONNECTION OF SOFTWARE UPGRADE	48
FIGURE 19: CONNECTION OF SOFTWARE DEBUG	48
FIGURE 20: RS232 LEVEL CONVERTER CIRCUIT	49
FIGURE 21: SPEAKER INTERFACE CONFIGURATION	50
FIGURE 22: SPEAKER INTERFACE WITH AMPLIFIER CONFIGURATION	51
FIGURE 23: MICROPHONE INTERFACE CONFIGURATION	51
FIGURE 24: EARPHONE INTERFACE CONFIGURATION	52
FIGURE 25: SIM INTERFACE REFERENCE CIRCUIT WITH 8-PIN SIM CARD	54
FIGURE 26: SIM INTERFACE REFERENCE CIRCUIT WITH 6-PIN SIM CARD	55
FIGURE 27: AMPHENOL C707-10M006 512 2 SIM CARD HOLDER	55
FIGURE 28: MOLEX 91228 SIM CARD HOLDER	56
FIGURE 29: THE GSM PART SERVICES AS RECEIVER	59
FIGURE 30: THE GSM PART SERVICES AS CALLER	59
FIGURE 31: REFERENCE CIRCUIT OF NETLIGHT	60
FIGURE 32: REFERENCE CIRCUIT OF BUZZER	61
FIGURE 33: THEORY OF OPERATION	62
FIGURE 34: TURN ON THE GPS MODULE	67
FIGURE 35: THEORY OF THE GPS RTC CIRCUIT	68
FIGURE 36: THEORY OF THE RESET CIRCUIT	68
FIGURE 37: RF CONNECTOR AND RF PAD	73
FIGURE 38: RF CONNECTOR	75
FIGURE 39: POWER DOWN MODE	81
FIGURE 40: PUSH-TO-FIX MODE	82
FIGURE 41: POWER CONSUMPTION IN THE PTF MODE	83
FIGURE 42: MECHANICAL DIMENSIONS OF MODULE (UNIT: MM)	85

SIM548C Hardware Design

FIGURE 43: MOUNT THE MODULE (UNIT: MM)	86
FIGURE 44: MECHANICAL DIMENSIONS OF MODULE PCB DECAL (UNIT: MM)	86
FIGURE 45: ASTRON1590060-09T-R BOARD TO BOARD CONNECTOR.....	87
FIGURE 46: ASTRON BOARD TO BOARD CONNECTOR PHYSICAL PHOTO	87
FIGURE 47: MM9329-2700B.....	88
FIGURE 48: RF CONNECTOR MXTK.....	88
FIGURE 49: PHYSICAL SIM548C.....	90
FIGURE 50: REFERENCE CIRCUIT WITH EXTERNAL MCU (STANDALONE APPLICATION FOR EXAMPLE).....	91
FIGURE 51: AGPS CONNECTION.....	92

SIMCOM CONFIDENTIAL FILE

Version History

Date	Version	Description of change	Author
2008-05-09	1.01	Origin	Tanshi

Scope of the document

This document is intended for the following versions of the SIMCom GSM/GPRS&GPS modules

- SIM548C: GSM/GPRS 850/900/1800 /1900MHz Version

1 Introduction

This document describes the hardware interface of the SIMCom SIM548C module that connects to the specific application and the air interface. As SIM548C can be integrated with a wide range of applications, all functional components of SIM548C are described in great detail.

This document can help you quickly understand SIM548C interface specifications, electrical and mechanical details. With the help of this document and other application notes, user guide, you can use SIM548C module to design and set-up mobile applications quickly.

1.1 Related documents

Table 1: Related documents

SN	Document name	Remark
[1]	SIM548C_ATC	SIM548C_ATC
[2]	GPS_AN01	GPS_AN01_GPS_Command_Examples
[3]	GPS_AN02	GPS_AN02_AGPS_Application
[4]	ITU-T Draft new recommendation V.25ter:	Serial asynchronous automatic dialing and control
[5]	GSM 07.07:	Digital cellular telecommunications (Phase 2+); AT command set for GSM Mobile Equipment (ME)
[6]	GSM 07.05:	Digital cellular telecommunications (Phase 2+); Use of Data Terminal Equipment – Data Circuit terminating Equipment (DTE – DCE) interface for Short Message Service (SMS) and Cell Broadcast Service (CBS)
[7]	GSM 07.10:	Support GSM 07.10 multiplexing protocol
[8]	GSM 11.14:	Digital cellular telecommunications system (Phase 2+); Specification of the SIM Application Toolkit for the Subscriber Identity Module – Mobile Equipment (SIM – ME) interface
[9]	GSM 11.11:	Digital cellular telecommunications system (Phase 2+);

		Specification of the Subscriber Identity Module – Mobile Equipment (SIM – ME) interface
[10]	GSM 03.38:	Digital cellular telecommunications system (Phase 2+); Alphabets and language-specific information
[11]	GSM 11.10	Digital cellular telecommunications system (Phase 2) ; Mobile Station (MS) conformance specification; Part 1: Conformance specification
[12]	AN SerialPport	AN SerialPport

1.2 Terms and abbreviations

Table 2: Terms and abbreviations

GSM PART	
Abbreviation	Description
ADC	Analog-to-Digital Converter
ARP	Antenna Reference Point
ASIC	Application Specific Integrated Circuit
BER	Bit Error Rate
BTS	Base Transceiver Station
CHAP	Challenge Handshake Authentication Protocol
CS	Coding Scheme
CSD	Circuit Switched Data
CTS	Clear to Send
DAC	Digital-to-Analog Converter
DRX	Discontinuous Reception
DSP	Digital Signal Processor
DTE	Data Terminal Equipment (typically computer, terminal, printer)
DTR	Data Terminal Ready
DTX	Discontinuous Transmission
EFR	Enhanced Full Rate
EGSM	Enhanced GSM
EMC	Electromagnetic Compatibility
ESD	Electrostatic Discharge
ETS	European Telecommunication Standard

SIM548C Hardware Design

FCC	Federal Communications Commission (U.S.)
FDMA	Frequency Division Multiple Access
FR	Full Rate
GMSK	Gaussian Minimum Shift Keying
GPRS	General Packet Radio Service
GSM	Global Standard for Mobile Communications
HR	Half Rate
I/O	Input/Output
IC	Integrated Circuit
IMEI	International Mobile Equipment Identity
kbps	Kilo bits per second
LED	Light Emitting Diode
Li-Ion	Lithium-Ion
MO	Mobile Originated
MS	Mobile Station (GSM engine), also referred to as TE
MT	Mobile Terminated
PAP	Password Authentication Protocol
PBCCH	Packet Switched Broadcast Control Channel
PCB	Printed Circuit Board
PCS	Personal Communication System, also referred to as GSM 1900
PDU	Protocol Data Unit
PPP	Point-to-point protocol
RF	Radio Frequency
RMS	Root Mean Square (value)
RP	Receive Protocol
RTC	Real Time Clock
Rx	Receive Direction
SA	Selective Availability
SAR	Specific Absorption Rate
SIM	Subscriber Identification Module
SMS	Short Message Service
TDMA	Time Division Multiple Access
TE	Terminal Equipment, also referred to as DTE
TX	Transmit Direction
URC	Unsolicited Result Code
USSD	Unstructured Supplementary Service Data
VSWR	Voltage Standing Wave Ratio
Vmax	Maximum Voltage Value

SIM548C Hardware Design

Vnorm	Normal Voltage Value
Vmin	Minimum Voltage Value
VIHmax	Maximum Input High Level Voltage Value
VIHmin	Minimum Input High Level Voltage Value
VILmax	Maximum Input Low Level Voltage Value
VILmin	Minimum Input Low Level Voltage Value
VImax	Absolute Maximum Input Voltage Value
VImin	Absolute Minimum Input Voltage Value
VOHmax	Maximum Output High Level Voltage Value
VOHmin	Minimum Output High Level Voltage Value
VOLmax	Maximum Output Low Level Voltage Value
VOLmin	Minimum Output Low Level Voltage Value
<i>Phonebook abbreviations</i>	
FD	SIM fix dialing phonebook
LD	SIM last dialing phonebook (list of numbers most recently dialed)
MC	Mobile Equipment list of unanswered MT calls (missed calls)
ME	Mobile Equipment phonebook
RC	Mobile Equipment list of received calls
SM	SIM phonebook
DC	ME dialed calls list(+CPBW may not be applicable or this storage)(same as LD)
LA	Last Number All list (LND/LNM/LNR)
ON	SIM (or ME) own numbers (MSISDNs) list
SD	SIM service dial number
VM	SIM voice mailbox
BN	SIM barred dialed number
GPS PART	
Abbreviation	Description
ATP	Adaptive Trickle Power mode.
DGPS	Differential GPS
GGA	GPS Fixed Data
GPS	Global Positioning System
LNA	Low Noise Amplifier
RTCM	Radio Technical Commission for Maritime Services

2 Overview

Designed for global market, SIM548C is a GSM/GPRS and GPS module. SIM548C with a Quad-band GSM/GPRS engine works on frequencies EGSM 900 MHz/DCS 1800 MHz and GSM850 MHz/PCS 1900 MHz. SIM548C also supports GPS technology for satellite navigation. SIM548C provides GPRS multi-slot class10 / class 8 (option) capabilities and supports the GPRS coding schemes CS-1, CS-2, CS-3 and CS-4.

With a tiny configuration of 50mm x 33mm x 8.8mm, SIM548C can meet almost all the space requirement in your application, such as smart phone, PDA phone, GPS hand-held device and other mobile device, or applications of AVL (Automated Vehicle Location), location service and so on.

The physical interface to the mobile application is an 60-pin board-to-board connector, which provides all hardware interfaces between the module and customers' boards except the RF antenna interface.

- The SPI display interface will give you the flexibility to develop customized applications.
- One serial GSM port and two serial GPS ports can help you easily develop your applications.
- Two audio channels include two microphones inputs and two speakers' outputs. These can be easily configured by AT command.
- Charge interface

With the charge circuit integrated inside the SIM548C, it is very suitable for the battery power application.

SIM548C provides GSM RF antenna interface with alternatives: antenna connector and antenna pad. The antenna connector is MURATA MM9329-2700 RA1. And customer's antenna can be soldered to the antenna pad. A separate GPS antenna must be connected to the GPS part of the module in order to properly receive satellite data.

The SIM548C is designed with power saving technique, so that the current consumption of GSM part maintains is as low as about 3mA in SLEEP mode.

The SIM548C is integrated with the TCP/IP protocol, extended TCP/IP AT commands are developed for customers to use the TCP/IP protocol easily, which is very useful for those data transfer applications.

The SIM548C is fully RoHS compliant to EU regulation.

2.1 Key features

Table 3: Key features

Feature	Implementation
Power supply	<ul style="list-style-type: none"> ● GSM part: Supply voltage 3.4V – 4.5V ● GPS part: Separate power supply source: 3.3V ± 5%
Power saving	<ul style="list-style-type: none"> ● GSM part: Typical power consumption in SLEEP mode to 3.5mA (BS-PA-MFRMS=5) ● GPS part: Power Down mode / Push-to-Fix mode
Charging	Supports charging control for Li-Ion battery
Frequency bands	<ul style="list-style-type: none"> ● EGSM 900/DCS 1800 and GSM850 MHz/PCS 1900 MHz. The SIM548C can search the frequency bands automatically. The frequency bands also can be set by AT command. ● Compliant to GSM Phase 2/2+
GSM class	Small MS
Transmitting power	<ul style="list-style-type: none"> ● Class 4 (2W) at EGSM 900/GSM 850 ● Class 1 (1W) at DCS 1800/PCS 1900
GPRS connectivity	<ul style="list-style-type: none"> ● GPRS multi-slot class 10 (default) ● GPRS multi-slot class 8 (option) ● GPRS mobile station class B
GPS features	<ul style="list-style-type: none"> ● GPS receiver with SiRFstar III chip set ● Processor type ARM7/TDMI
Temperature range	<ul style="list-style-type: none"> ● Operation Temperature: Normal operation: -30°C to +80°C Restricted operation: -40°C to -30°C and +80°C to +85°C⁽¹⁾ ● Storage temperature -45°C to +90°C
DATA GPRS:	<ul style="list-style-type: none"> ● GPRS data downlink transfer: max. 85.6 kbps ● GPRS data uplink transfer: max. 42.8 kbps ● Coding scheme: CS-1, CS-2, CS-3 and CS-4 ● SIM548C supports the protocols PAP (Password Authentication Protocol) usually used for PPP connections. ● The SIM548C integrates the TCP/IP protocol.

CSD:	<ul style="list-style-type: none"> ● Support Packet Switched Broadcast Control Channel (PBCCH) ● CSD transmission rates: 2.4, 4.8, 9.6, 14.4 kbps, non-transparent ● Unstructured Supplementary Services Data (USSD) support
SMS	<ul style="list-style-type: none"> ● MT, MO, CB, Text and PDU mode ● SMS storage: SIM card
FAX	Group 3 Class 1
SIM interface	Support SIM card: 1.8V ,3V
External antenna	<ul style="list-style-type: none"> ● GSM part: Connected via 50 Ohm antenna connector or antenna pad ● GPS part: Separate GPS antenna connector. Please refer to figure 33 for details
Audio features	<p>Speech codec modes:</p> <ul style="list-style-type: none"> ● Half Rate (ETS 06.20) ● Full Rate (ETS 06.10) ● Enhanced Full Rate (ETS 06.50 / 06.60 / 06.80) ● Adaptive multi rate (AMR) ● Echo Cancellation
Serial GSM port and Debug port	<ul style="list-style-type: none"> ● Serial port: Seven lines on Serial Port Interface ● Serial Port can be used for CSD FAX, GPRS service and send AT command of controlling module. ● Serial Port can use multiplexing function ● Autobauding supports baud rate from 4800 bps to 115200bps. ● Debug Port: Two lines on debug port interface DBG_TXD and DBG_RXD ● Debug Port only used for debugging
Two serial GPS port	<ul style="list-style-type: none"> ● Serial Port A: Two lines on Serial Port A, GPS_TXA and GPS_RXA ● Serial Port B: Two lines on Serial Port B, GPS_TXB and GPS_RXB
Phonebook management	Support phonebook types: SM, FD, LD, MC, RC, ON, ME,BN,VM,LA,DC,SD
SIM Application Toolkit	Support SAT class 3, GSM 11.14 Release 99
Real time clock	Implemented

SIM548C Hardware Design

Timer function	Programmable via AT command
Physical characteristics	Size: 50±0.15 x 33±0.15 x 10.3±0.3mm (including application connector) 50±0.15 x 33±0.15 x 8.8±0.3mm (excluding application connector) Weight: 16.5g
Firmware upgrade	Firmware upgrade by serial port

(1) The module does work, but deviations from the GSM specification may occur, For example, both the frequency error and the phase error will be large.

Table 4: Coding schemes and maximum net data rates over air interface

Coding scheme	1 Timeslot	2 Timeslot	4 Timeslot
CS-1:	9.05kbps	18.1kbps	36.2kbps
CS-2:	13.4kbps	26.8kbps	53.6kbps
CS-3:	15.6kbps	31.2kbps	62.4kbps
CS-4:	21.4kbps	42.8kbps	85.6kbps

2.2 Functional diagram

The SIM548C have two circuits parts (GSM part and GPS part) which are place on one PCB and have only one connector .The following figure shows a functional diagram of the SIM548C and illustrates the mainly functional part:

GSM part:

- The GSM baseband engine
- Flash and SRAM
- The GSM radio frequency part
- The antenna interface
- The board-to-board interface

GPS part:

- The SIRFIII GPS engine
- The GPS radio frequency part
- The antenna interface
- The board-to-board interface

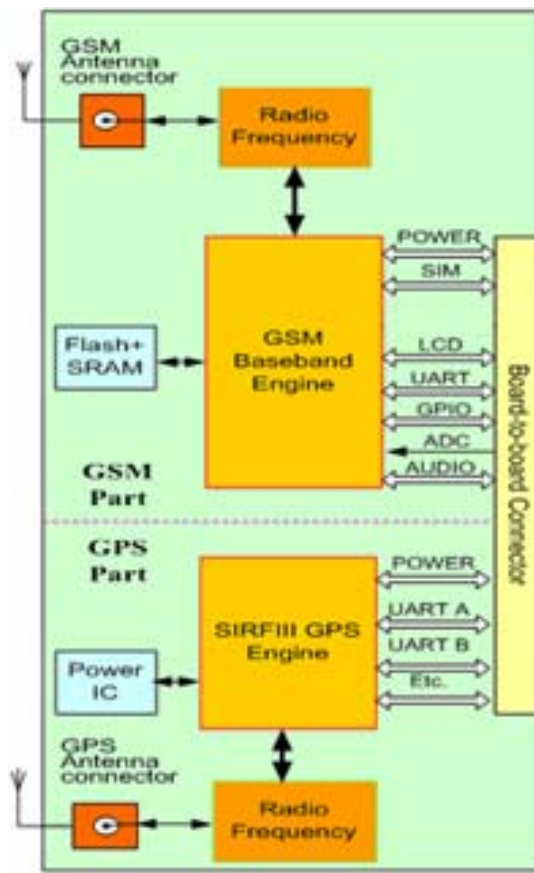

Figure 1: Functional diagram

2.3 Evaluation board

In order to help you on the application of SIM548C, SIMCom can supply an Evaluation Board (EVB) that interfaces the SIM548C directly with appropriate power supply, SIM card holder, RS232 serial port, handset port, earphone port, antenna and all GPIOs of the SIM548C.

For details please refer to the SIM548C-EVB_UGD document.

3 GSM application interface

All hardware interfaces except RF interface that connects SIM548C to the customers' cellular application platform is through a 60-pin 1.27mm pitch board-to-board connector. Sub-interfaces included in this board-to-board connector are described in detail in following chapters:

- Power supply and charging control
- GSM serial interface
- Two analog audio interfaces
- SIM interface

Electrical and mechanical characteristics of the board-to-board connector are specified in *Chapter 6*. There are also ordering information for mating connectors.

3.1 Pin description

Table 5: Board-to-Board connector pin description

Power Supply			
PIN NAME	I/O	DESCRIPTION	DC CHARACTERISTICS
VBAT		4 VBAT pins of the board-to-board connector are dedicated to connect the supply voltage. The power supply of the GSM part of 548C has to be a single voltage source of VBAT=3.4V...4.5V. It must be able to provide sufficient current in a transmitting burst which typically rises to 2A, mostly. These 4 pins are voltage input	Vmax= 4.5V Vmin=3.4V Vnorm=4.0V
VRTC	I/O	RTC current input from the backup battery when the VBAT is not supplied for the system. Current output to backup battery when the main battery is present and the backup battery is low voltage state.	Vmax=2.0V Vmin=1.2V Vnorm=1.8V Inorm= 20uA
VCHG	I	Voltage input for the charge circuit; making the system detect the charger.	Vmax=5.25V Vmin=1.1 * VBAT Vnorm=5.1V

SIM548C Hardware Design

GND		Digital ground	
Power on or power off			
PIN NAME	I/O	DESCRIPTION	DC CHARACTERISTICS
PWRKEY	I	Voltage input for PWRKEY. PWRKEY should be pull low to power on or power off the system. The user should keep pressing the key for a moment when power on or power off the system. because the system need margin time in order to assert the software.	$V_{ILmax}=0.2*V_{BAT}$ $V_{IHmin}=0.6*V_{BAT}$ $V_{Imax}=V_{BAT}$
Audio interface			
PIN NAME	I/O	DESCRIPTION	DC CHARACTERISTICS
MIC1P MIC1N	I	Positive and negative voice-band input	Audio DC Characteristics refer to chapter 3.9.4
MIC2P MIC2N	I	Auxiliary positive and negative voice-band input	
SPK1P SPK1N	O	Positive and negative voice-band output	
SPK2P SPK2N	O	Auxiliary positive and negative voice-band output	
BUZZER	O	Buzzer output	
AGND		Analog ground	
Display interface			
DISP_DATA	I/O	LCD display interface	$V_{ILmin}=0V$
DISP_CLK	O		$V_{ILmax}=0.9V$
DISP_D/C	O		$V_{IHmin}=2.0V$
DISP_CS	O		$V_{IHmax}=3.2V$
DISP_RST	O		$V_{OLmin}=GND$
			$V_{OLmax}=0.2V$
			$V_{OHmin}=2.7V$
			$V_{OHmax}=2.9V$
GERNERAL PURPOSE input/output			
PIN NAME	I/O	DESCRIPTION	DC CHARACTERISTICS
NETLIGHT	O	Network status indication	$V_{ILmin}=0V$
STATUS	O	Another indication for system on/off	$V_{ILmax}=0.9V$
GPI00	I/O	General purpose input/output port	$V_{IHmin}=2.0V$
GPI01	I/O	General purpose input/output port	$V_{IHmax}=3.2V$
			$V_{OLmin}=GND$
			$V_{OLmax}=0.2V$
			$V_{OHmin}=2.7V$
			$V_{OHmax}=2.9V$

Serial port			
PIN NAME	I/O	DESCRIPTION	DC CHARACTERISTICS
DTR	I	Data terminal ready	$V_{ILmin}=0V$
RXD	I	Receive data	$V_{ILmax}=0.9V$
TXD	O	Transmit data	$V_{IHmin}=2.0V$
RTS	I	Request to send	$V_{IHmax}=3.2V$
CTS	O	Clear to send	$V_{OLmin}=GND$
RI	O	Ring indicator	$V_{OLmax}=0.2V$
DCD	O	Data carrier detection	$V_{OHmin}=2.7V$
			$V_{OHmax}=2.9V$
Debug port			
DBG_TXD	O	Serial interface for debugging only	
DBG_RXD	I		
SIM interface			
PIN NAME	I/O	DESCRIPTION	DC CHARACTERISTICS
SIM_VDD	O	Voltage supply for SIM card	The voltage can be select by software automatically either 1.8V or 3V
SIM_DATA	I/O	SIM data output	$V_{ILmin}=0V$
SIM_CLK	O	SIM clock	$V_{ILmax}=0.3 * SIM_VDD$
SIM_PRESENCE	I	SIM card detection	$V_{IHmin}=0.7 * SIM_VDD$
SIM_RST	O	SIM reset	$V_{IHmax}=SIM_VDD + 0.3$
			$V_{OLmin}=GND$
			$V_{OLmax}=0.2V$
			$V_{OHmin}=SIM_VDD - 0.2$
			$V_{OHmax}=SIM_VDD$
AUXADC			
PIN NAME	I/O	DESCRIPTION	DC CHARACTERISTICS
ADC0	I	General purpose analog to digital converter.	Input voltage range: 0V to 2.4V
TEMP_BAT	I	For measure the battery temperature	0-1.2V

3.2 Operating modes

The table below briefly summarizes the various operating modes referred to in the following chapters.

Table 6: Overview of operating modes

Mode	Function
Normal operation	<p>GSM/GPRS SLEEP</p> <p>Module will automatically go into SLEEP mode if DTR is set to high level and there is no on air hardware interrupt (such as GPIO interrupt or data on serial port).</p> <p>In this case, the current consumption of module will reduce to the minimal level.</p> <p>During SLEEP mode, the module can still receive paging message and SMS from the system normally.</p>
	<p>GSM IDLE</p> <p>Software is active. Module has registered to the GSM network, and the module is ready to send and receive.</p>
	<p>GSM TALK</p> <p>Connection is going on between two subscribers. In this case, the power consumption depends on network settings such as DTX off/on, FR/EFR/HR, hopping sequences, antenna.</p>
	<p>GPRS STANDBY</p> <p>Module is ready for GPRS data transfer, but no data is currently sent or received. In this case, power consumption depends on network settings and GPRS configuration.</p>
	<p>GPRS DATA</p> <p>There is GPRS data in transfer (PPP or TCP or UDP). In this case, power consumption is related with network settings (e.g. power control level), uplink / downlink data rates and GPRS configuration (e.g. used multi-slot settings).</p>
POWER DOWN	<p>Normal shutdown by sending the “AT+CPOWD” command or using the PWRKEY. The power management ASIC disconnects the power supply from the base band part of the module, and only the power supply for the RTC is remained. Software is not active. The serial port is not accessible. Operating voltage (connected to VBAT) remains applied.</p>
Minimum functionality mode (without remove power supply)	<p>Use the “AT+CFUN” command can set the module to a minimum functionality mode without remove the power supply. In this case, the RF part of the module will not work and the SIM card will not be accessible, or both RF part and SIM card will be closed all, and the serial port is still accessible. The power consumption in this case is very low.</p>
Alarm mode	<p>RTC alert function launches this restricted operation while the module is in POWER DOWN mode. The module will not be registered to GSM network and</p>

	only parts of AT commands can be available.
GHOST Mode (Charge-only mode)	<p>GHOST mode means off and charging mode. In this mode, the module can not be registered to GSM network and only limited AT commands can be accessible, the following way will launch GHOST mode:</p> <ul style="list-style-type: none"> ● From POWER DOWN mode: Connect charger to the module's VCHG pin, and battery is present while the module is power down. ● From Normal mode: Connect charger to the module's VCHG pin, and battery is present, then power down the module by "AT+CPOWD=1"
Charge mode during normal operation	Start charging while the module is in normal mode (including: SLEEP, IDLE, TALK, GPRS IDLE and GPRS DATA)

3.3 Power supply

The power supply of SIM548C GSM part is from a single voltage source of $V_{BAT} = 3.4V \dots 4.5V$. In some case, the ripple in a transmitting burst may cause voltage drops when current consumption rise to typical peaks of 2A. So the power supply must be able to provide sufficient current up to 2A.

For the VBAT input, a local bypass capacitor is recommended. A capacitor (about $100\mu F$, low ESR) is recommended. Multi-layer ceramic chip (MLCC) capacitors can provide the best combination of low ESR and small size but may not be cost effective. A lower cost choice may be a $100\mu F$ tantalum capacitor (low ESR) with a small ($0.1\mu F$ to $1\mu F$) ceramic in parallel, which is illustrated as following figure. The capacitors should put as close as possible to the module VBAT pins.

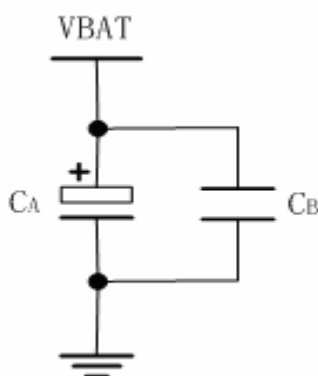

Figure 2: Reference circuit of the VBAT input

SIM548C Hardware Design

The circuit design of the power supply depends strongly on the power source where this power is drained. The following figure is the reference design of +5V input source power supply. The designed output for the power supply is 4V, thus a linear regulator can be used. If there's a big difference between the input source and the desired output (VBAT), a switching converter power supply will be preferable because of its better efficiency especially with the 2A peak current in burst mode of the module.

The single 3.6V Li-Ion cell battery type can be connected to the power supply of the module VBAT directly. But the Ni_Cd or Ni_MH battery types must be used carefully, since their maximum voltage can rise over the absolute maximum voltage for the module and damage it.

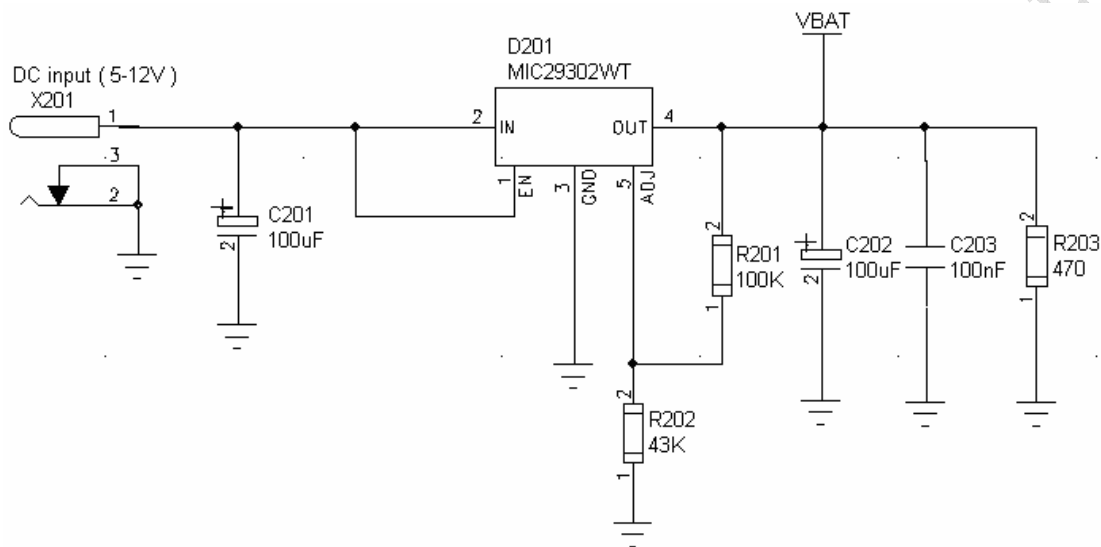

Figure 3: Reference circuit of the source power supply input

The following figure is the VBAT voltage ripple wave at the maximum power transmit phase, the test condition is VBAT=4.0V, VBAT maximum output current =2A, $C_A=100\mu\text{F}$ tantalum capacitor (ESR=0.7 Ω) and $C_B=1\mu\text{F}$.

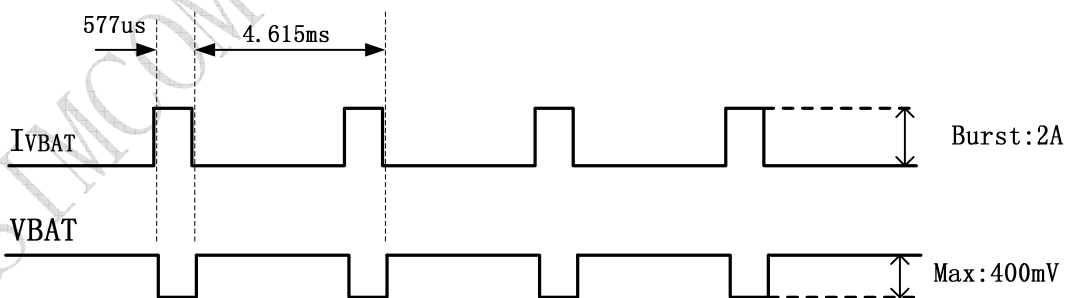

Figure 4: VBAT voltage drop during transmit burst

3.3.1 Power supply pins on the board-to-board connector

Four VBAT pins of the board-to-board connector are dedicated to connect the supply voltage. The VCHG pin serves as control signal for charging a Li-Ion battery. VRTC pin can be used to back up the RTC.

3.3.2 Minimizing power losses

Please pay special attention to the supply power when you are designing your applications. Please make sure that the input voltage will never drop below 3.4V even in a transmitting burst during which the current consumption may rise up to 2A. If the power voltage drops below 3.4V, the module may be switched off. So the impedance from external power supply to module VBAT pins should be as low as possible. When using a battery, you should also take the impedance of the battery pack, the battery connector and PCB track on the host board into account. The PCB traces from the VBAT pins of connector to the power source must be wide enough to ensure less voltage drops occur in the transmitting burst mode.

3.3.3 Monitoring power supply

To monitor the supply voltage, you can use the “AT+CBC” command which include three parameters: charging status, voltage percentage and voltage value (in mV). It returns charge state, the battery voltage 1-100 percent of capacity and actual value measured at VBAT and GND.

The voltage is continuously measured at intervals depending on the operating mode. The displayed voltage (in mV) is averaged over the last measuring period before the AT+CBC command is executed.

For details please refer to *document [1]*

3.4 Power up and down scenarios

3.4.1 Turn on the GSM part

The GSM part of SIM548C can be turned on by various ways, which are described in following chapters:

- Via PWRKEY pin: starts normal operating mode;
- Via VCHG pin: starts GHOST modes;
- Via RTC interrupt: starts ALARM modes

Note:

Only enter AT command through serial port after the module is power on and Unsolicited Result Code “RDY” is received from serial port. However if autobauding is set, the serial port will receive nothing. The AT command can be set after 2-3s from the GSM part is power on. You can use AT+IPR=x;&W to set a fixed baud rate and save the configuration to non-volatile flash memory. After the configuration is saved as fixed baud rate, the Code “RDY” should be received from the serial port all the time when the GSM part is power on. Please refer to the chapter AT+IPR in document [1].

3.4.1.1 Turn on the GSM part using the PWRKEY pin (Power on)

You can turn on the GSM part of the module by driving the PWRKEY to a low level voltage for some time and then release. This pin is pulled up to VBAT in the module. The maximum current that can be drained from the PWRKEY pin is 0.4mA. The simple circuit illustrates as the following figures.

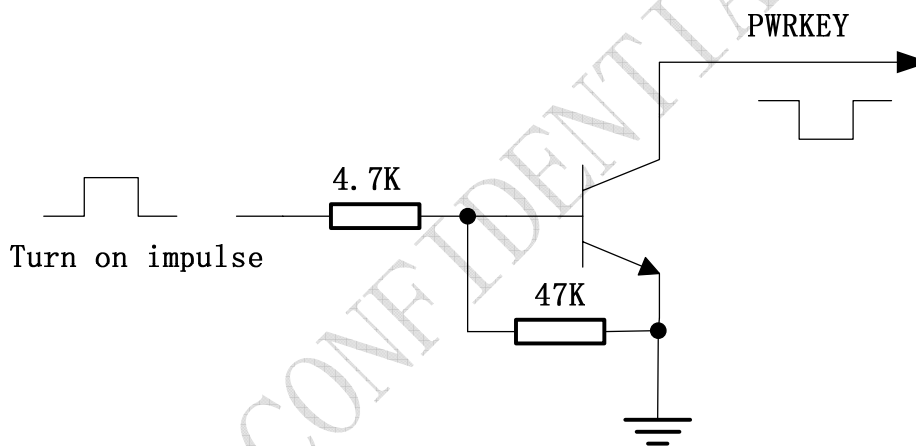

Figure 5: Turn on GSM part using driving circuit

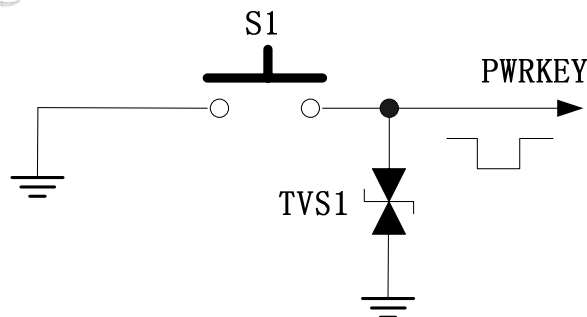

Figure 6: Turn on GSM part using button

The power on scenarios illustrates as following figure.

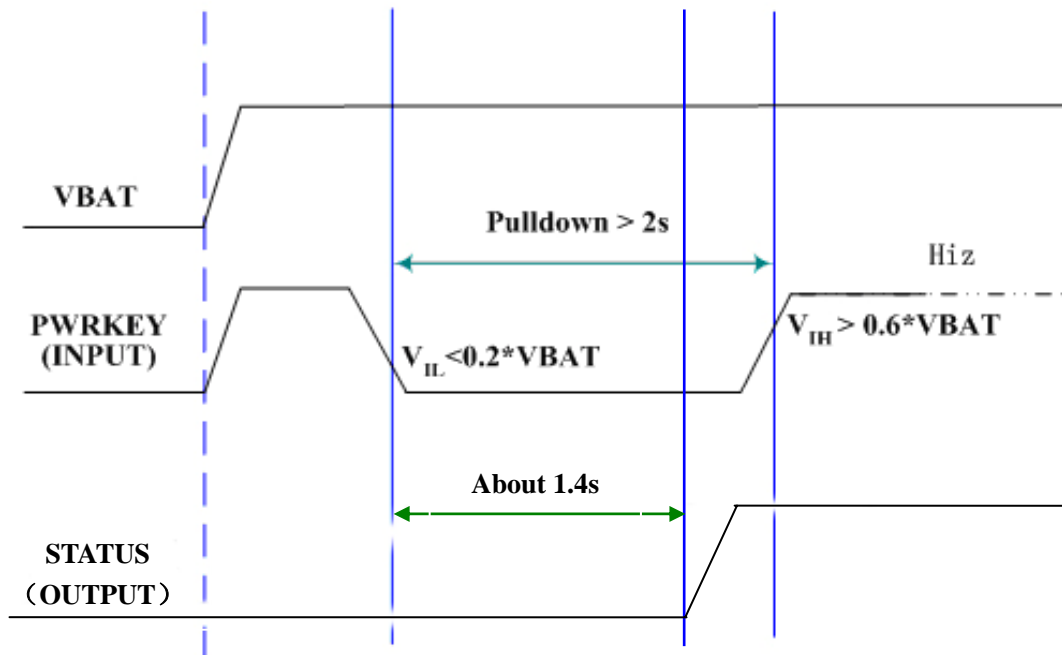

Figure 7: Timing of turn on GSM part

When power on procedure complete, the GSM part of SIM548C will send out following result code to indicate the module is ready to operate, and STATUS pin will drive to 2.8V and keep this level when in work mode.

RDY

Only set baud rate that serial port can send out “RDY”, if set auto-baud rate, serial port will send nothing.

3.4.1.2 Turn on the GSM part using the VCHG signal

As described in chapter 3.5, charger can be connected to the GSM part of the module’s VCHG pin regardless of the module’s operating mode.

If the charger is connected to the module’s VCHG pin while the GSM part of the module is in POWER DOWN mode, it will go into the GHOST mode (Off and charging). In this mode, the module will not register to network, and only a few AT commands can work in this mode. For detailed information please refers to chapter 3.5.4.

When the module is powered on using the VCHG signal, the GSM part of the module sends out result code as following when fixed baud rate:

RDY

GHOST MODE

+CFUN: 0

In GHOST mode, by driving the PWRKEY to a low level voltage for some time (Please refer to the power on scenarios in 3.4.1.1), the GSM part of SIM548C will power up and go into charge mode (charging in normal mode), all operation and AT commands can be available. In this case, the GSM part of SIM548C will send out result code as following:

From GHOST MODE to NORMAL MODE

3.4.1.3 Turn on the GSM part using the RTC (Alarm mode)

Alarm mode is a power-on approach by using the RTC. The alert function of RTC makes the GSM part of the module wake up while the module is power off. In alarm mode, the GSM part of the module will not register to GSM network and the software protocol stack is close. Thus the parts of AT commands related with SIM card and Protocol stack will not accessible, and the others can be used as well as in normal mode.

Use the AT+CALARM command to set the alarm time. The RTC remains the alarm time if the GSM part of the module is power down by “AT+CPOWD=1” or by PWRKEY pin. Once the alarm time is expired and executed, the GSM part of the module will go into the Alarm mode. In this case, the GSM part of the module will send out an Unsolicited Result Code (URC):

RDY

ALARM MODE

During alarm mode, use AT+CFUN command to query the status of software protocol stack; it will return 0 which indicates that the protocol stack is closed. Then after 90s, the GSM part of the module will power down automatically. However, during alarm mode, if the software protocol is started by AT+CFUN=1 command, the process of automatic power down will not be available. In ALARM mode, driving the PWRKEY to a low level voltage for a period will cause the GSM part of the module to be powered down (Please refer to the power down scenario).

The table follow briefly summarizes the AT commands that are used usually during alarm mode,

for details of the instructions refer to *document [1]*:

Table 7: AT commands used in Alarm mode

AT command	USE
AT+CALARM	Set alarm time
AT+CCLK	Set data and time of RTC
AT+CPOWD	Power down
AT+CFUN	Start or close the protocol stack

3.4.2 Turn off the GSM part

Following procedure can be used to turn off the GSM part of SIM548C:

- Normal power down procedure: Turn off the GSM part of SIM548C using the PWRKEY pin
- Normal power down procedure: Turn off the GSM part of SIM548C using AT command
- Over-voltage or under-voltage automatic shutdown: Take effect if over-voltage or under-voltage is detected
- Over-temperature or under-temperature Automatic shutdown: Take effect if over-temperature or under-temperature is detected

3.4.2.1 Turn off the GSM part using the PWRKEY pin (Power down)

You can turn off the GSM part of SIM548C by driving the PWRKEY to a low level voltage for some time. Please refer to the turn on circuit. The power down scenarios illustrate as figure 4.

This procedure lets the module log off from the network and allows the software to enter into a secure state and save data before completely disconnecting the power supply.

Before the completion of the switching off procedure the module will send out result code:

NORMAL POWER DOWN

After this moment, the AT commands can't be executed. The module enters the POWER DOWN mode, only the RTC is still active. POWER DOWN can also be indicated by STATUS pin, which is a low level voltage in this mode.

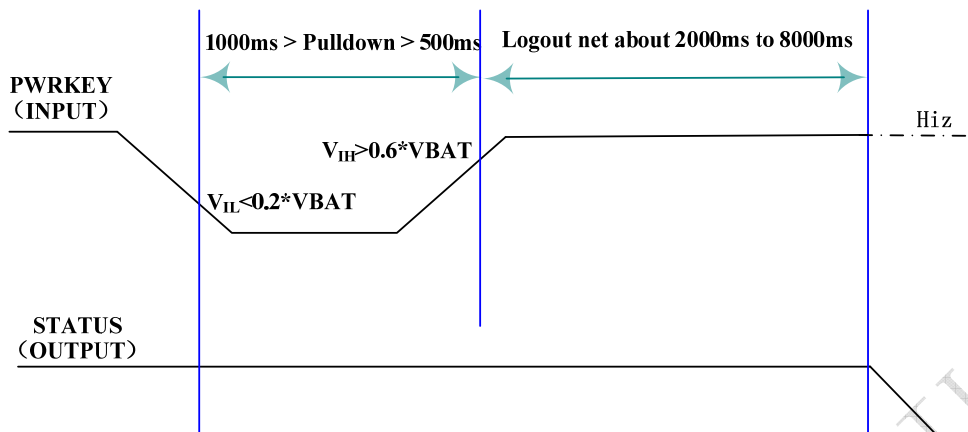

Figure 8: Timing of turn off GSM part

3.4.2.2 Turn off the GSM part using AT command

You can use an AT command “AT+CPOWD=1” to turn off the module. This command lets the module to log off from the network and allows the GSM part to enter into a secure state and save data before completely disconnecting the power supply.

Before the completion of the switching off procedure, the module will send out result code:

NORMAL POWER DOWN

After this moment, the commands can't be executed. The GSM part enters the POWER DOWN mode, only the RTC is still active. POWER DOWN can also be indicated by STATUS pin, which is a low level voltage in this mode.

Please refer to *document [1]* for detail about the AT command of “AT+CPOWD”.

3.4.2.3 Over-voltage or under-voltage automatic shutdown

The module will constantly monitor the voltage applied on the VBAT, if the voltage $\leq 3.5V$, the following URC will be presented:

UNDER-VOLTAGE WARNING

If the voltage $\geq 4.5V$, the following URC will be presented:

OVER-VOLTAGE WARNING

The uncritical voltage range is 3.4V to 4.6V. If the voltage $\geq 4.6V$ or $\leq 3.4V$, the module will

be automatic shutdown soon.

If the voltage $\leq 3.4V$, the following URC will be presented:

UNDER-VOLTAGE POWER DOWN

If the voltage $\geq 4.6V$, the following URC will be presented:

OVER-VOLTAGE POWER DOWN

After this moment, no further more AT commands can be executed. The module logs off from network and enters POWER DOWN mode, and only the RTC is still active. POWER DOWN can also be indicated by STATUS pin, which is a low level voltage in this mode.

3.4.2.4 Over-temperature or under-temperature automatic shutdown

The GSM part will constantly monitor the temperature of the module, if the temperature is equal or higher than $85^{\circ}C$, the following URC will be presented:

+CMTE:1

If the temperature $\leq -40^{\circ}C$, the following URC will be presented:

+CMTE:-1

The uncritical temperature range is $-45^{\circ}C$ to $90^{\circ}C$. If the temperature $\geq 90^{\circ}C$ or $\leq -45^{\circ}C$, the module will be automatic shutdown soon.

If the temperature $\geq 90^{\circ}C$, the following URC will be presented:

+CMTE:2

If the temperature $\leq -45^{\circ}C$, the following URC will be presented:

+CMTE:-2

After this moment, the AT commands can't be executed. The module logs off from network and enters POWER DOWN mode, and only the RTC is still active. POWER DOWN can also be indicated by STATUS pin, which is a low level voltage in this mode.

To monitor the temperature, you can use the "AT+CMTE" command to read the temperature when the module is power on.

For details please refer to *document [1]*

3.4.3 Restart the GSM part using the PWRKEY pin

You can restart the module by driving the PWRKEY to a low level voltage for some time, the same as turning on the module using the PWRKEY pin. Before restarting the module, you need delay at least 500ms from detecting the STATUS low level on. The restarting scenarios illustrates as the following figure.

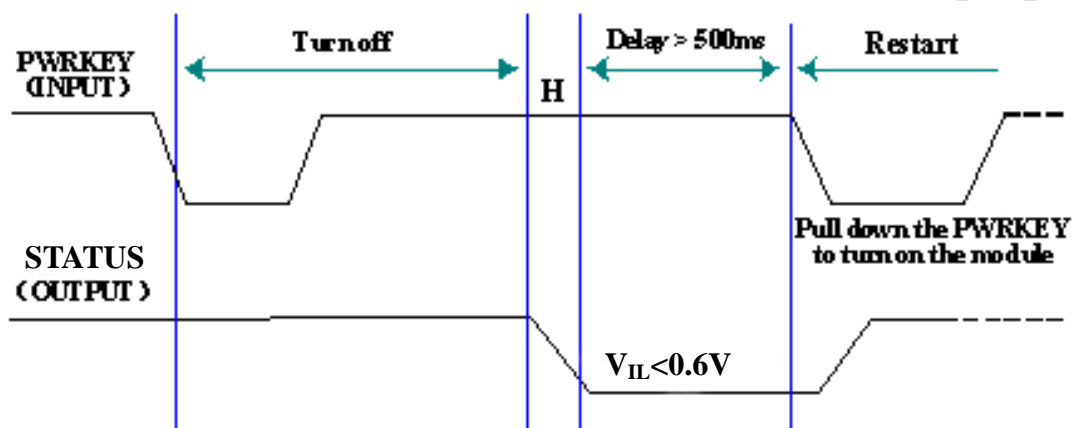

Figure 9: Timing of restart GSM part

3.5 Charging interface

The GSM part of the module has integrated a charging circuit for Li-Ion batteries charging control, which make it very convenient for applications to manage their battery charging.

A common connection is shown in the following figure:

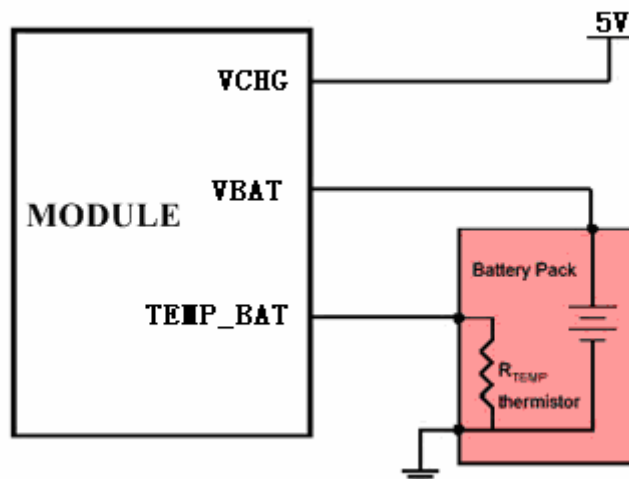

Figure 10: Battery charger and pack

The TEMP_BAT function should be supported by the software in the module. It's a customization function. The R_{TEMP} is a NTC thermistor. We recommend to use NCP15XH103F03RC from MURATA. The impedance of the NTC thermistor is 10Kohm in 25°C. Please refer to the above figure for the reference circuit.

3.5.1 Battery pack characteristics

The GSM part of the module has optimized the charging algorithm for the Li-Ion battery that meets the characteristics listed below. To use the GSM part of the module's charging algorithm properly, it is recommended that the battery pack you integrated into your application is compliant with these specifications. The battery pack compliant with these specifications is also important for the AT command "AT+CBC" to monitor the voltage of battery, or the "AT+CBC" may return incorrect battery capacity values.

- The maximum charging voltage of the Li-Ion battery pack is 4.2V and the capacity is recommended to 580mAh. The capacity of battery packs down to 580mAh or more than 580mAh are allowed, too.
- The battery pack should have a protection circuit to avoid overcharging, overdischarging and over-current. This circuit should be insensitive to pulsed current.
- On the GSM part of the module, the build-in power management chipset monitors the supply voltage constantly. Once the Under-voltage is detected, the GSM part of the module will power down automatically. Under-voltage thresholds are specific to the battery pack.
- The internal resistance of the battery and the protection circuit should be as low as possible.

SIM548C Hardware Design

It is recommended that the battery internal resistance should not exceed 70mΩ and the internal resistance include battery and protection circuit of battery pack should not exceed 130mΩ.

- The battery pack must be protected from reverse pole connection.
- The Li-Lon/Polymer battery charge protect parameter is required as following table

Table 8: recommended battery protect circuit parameter

Item	Min.	Typ.	Max.
Over-charge protect threshold.(V)	4.25	4.3	4.35
Released Voltage from Over-charge(V)	4.1		4.2
Over-discharge protect threshold(V)	2.2		2.35
Released Voltage from Over-discharge(V)	2.35	2.4	2.45

3.5.2 Recommended battery pack

Following is the spec of recommended battery pack:

Table 9: Spec of recommended battery pack

SIMCOM CONFIDENTIAL

SIM548C Hardware Design

Product name & type	SCUD Li-Ion, 3.7V, 800mAh
To obtain more information, Please contact :	SCUD (FU JIAN) Electronic CO..LTD
Normal voltage	3.7V
Capacity	Minimum 800mAh
Charge Voltage	4.200~4.23V
Max Charge Current	1.2C
Max Discharge Current	2C
Charge Method	CC / CV (Constant Current / Constant Voltage)
Internal resistance	$\leq 130\text{m}\Omega$
Over-charge protect threshold.(V)	4.28 ± 0.025
Released Voltage from Over-charge(V)	4.08 ± 0.05
Over-discharge protect threshold(V)	2.3 ± 0.1
Released Voltage from Over-discharge(V)	2.3 ± 0.1

3.5.3 Implemented charging technique

The GSM part of the module includes the function for battery charging. There are three pins in the connector related with the battery charging function: VCHG, VBAT and TEMP_BAT pins. The VCHG pin is driven by an external voltage, this pin can be used to detect a external charger supply and provide most charging current through the GSM part of the module to battery when charging is in fast charge state. The module VBAT pin give out charging current from the GSM part of the module to external battery. TEMP_BAT pin is used for measuring the battery temperature. Just let this pin open if battery temperature measuring is not your concern. So it is very simple to implement charging technique, you need only connect the charger to the VCHG pin and connect the battery to the VBAT pin.

When the GSM part of the module detected the charger supply and the battery are both present, battery charging will happen. If there is no charger supply or no battery present, the charging will not be enabled.

Normally, there are three main states in whole charging procedure.

- DDLO charge and UVLO charge;
- Fast charge;
- Trickle charge;

DDLO charge and UVLO charge:

DDLO (deep discharge lock out) is the state of battery when its voltage under 2.4V. And UVLO (under voltage lock out) means the battery voltage less than 3.2V and more than 2.4V. The battery is not suitable for fast charge when its condition is DDLO or UVLO. The GSM part of the module provides a small constant current to the battery when the battery is in DDLO or UVLO. In DDLO charge, The GSM part of the module gives out 5mA current to the battery. And in UVLO charge, The GSM part of the module provide about 30mA current to the battery.

DDLO charge terminated when the battery voltage reaches 2.4V. UVLO charge terminated when the battery voltage is up to 3.2V. Both DDLO and UVLO charge are controlled by the GSM part of the module hardware only.

Fast charge:

If there is a charger supply and battery present and the battery is not in DDLO and UVLO, the GSM part of the module will enter fast charge state. Fast charge controlled by the software. Fast charge delivers a strong and constant current (about 450mA) through VBAT pin to the battery until battery voltage reach 4.2V.

Trickle charge:

After fast charging, the battery voltage is approach the whole battery capacity voltage, trick charge begins .in this state, the GSM part of the module charge the battery under constant voltage.

3.5.4 Operating modes during charging

The battery can be charged during various operating mode. That means that when the GSM engine is in Normal mode (SLEEP, IDLE, TALK, GPRS IDLE or GPRS DATA mode), charging can be in progress while the GSM part of the module remains operational (In this case the voltage supply should be sufficient). Here we name Charging in Normal mode as Charge mode.

If a charger is connected to the module's VCHG pin and the battery is connected to the VBAT pin while the GSM part of the module is in POWER DOWN mode, the GSM part of the module will go into the GHOST mode (Off and charging). The following table gives the difference between Charge mode and GHOST mode.

Table 10: operating modes

	How to activate mode	Features
Charge Mode	Connect charger to module's VCHG pin and connect battery to VBAT pin of module while the GSM part of the module is in Normal operating mode, including: IDLE, TALK mode; SLEEP mode etc;	<ul style="list-style-type: none"> ● GSM remains operational and registered GSM network while charging is in progress; ● The serial interfaces are available in IDLE, TALK mode, the AT command set can be used fully in this case; <p>In SLEEP mode, the serial interfaces are not available, once the serial port is connected and there is data in transfer. Then the GSM part of the module will exit the SLEEP mode.</p>
GHOST Mode	<p>Connect charger to module's VCHG pin while the GSM part of the module is in POWER DOWN mode.</p> <p>IMPORTANT: In GHOST mode not all the software tasks are running.</p>	<ul style="list-style-type: none"> ● Battery can be charged when GSM engine is not registered to GSM network; ● Only a few AT commands is available as listed below.

Note:

VBAT can not provide much more than 5mA current while the module is during the DDLO charge state. In other words it is strongly recommended that VBAT should not be the main power supply in the application subsystem while the module is during the DDLO charge state.

Table 11: AT Command usually used in GHOST mode

SIM548C Hardware Design

AT command	Function
AT+CALARM	Set alarm time
AT+CCLK	Set data and time of RTC
AT+CPOWD	Power down
AT+CBC	Indicated charge state and voltage
AT+CFUN	Start or close the protocol Set AT command“ AT+CFUN =1”,module can be transferred from GHOST mode to Charging in normal mode, In GHOST mode , the default value is

3.5.5 Charger requirements

Following is the requirements of charger for the GSM part of the module.

- Simple transformer power plug
- Output voltage: 5.0V-5.25V
- Charging current limitation: 650mA
- A 10V peak voltage is allowed for maximum 1ms when charging current is switched off.
- A 1.6A peak current is allowed for maximum 1ms when charging current is switched on.

3.6 Power saving

There are two methods for the module to enter into low current consumption status. “AT+CFUN” is used to set module into minimum functionality mode and DTR hardware interface signal can be used to lead system to be in SLEEP mode (or slow clocking mode).

3.6.1 Minimum functionality mode

Minimum functionality mode reduces the functionality of the module to a minimum and, thus, minimizes the current consumption to the lowest level. This mode is set with the “AT+CFUN” command which provides the choice of the functionality levels <fun>=0, 1, 4

- 0: minimum functionality;
- 1: full functionality (default);

- 4: disable phone both transmit and receive RF circuits;

If the GSM part of the module has been set to minimum functionality by “AT+CFUN=0”, then the RF function and SIM card function will be closed. In this case, the serial port is still accessible, but all AT commands need RF function or SIM card function will not be accessible.

If the GSM part of the module has been set by “AT+CFUN=4”, the RF function will be closed, the serial port is still active. In this case but all AT commands need RF function will not accessible.

After the GSM part of the module has been set by “AT+CFUN=0” or “AT+CFUN=4”, it can return to full functionality by “AT+CFUN=1”

For detailed information about “AT+CFUN”, please refer to *document [1]*.

3.6.2 SLEEP mode (slow clock mode)

We can control the GSM part of the module to enter or exit the SLEEP mode in customer applications through DTR signal.

When DTR is in high level and there is no on air and hardware interrupt (such as GPIO interrupt or data on serial port), the GSM part of the module will enter SLEEP mode automatically. In this mode, the GSM part of the module can still receive paging or SMS from network.

In SLEEP mode, the serial port is not accessible.

Note: For some special software versions, it requests to set AT command “AT+CSCLK=1” to enable the sleep mode; the default value is 0, that can’t make the module enter sleep mode. For more details please refer to our AT command list.

3.6.3 Wake up the GSM part from SLEEP mode

When the GSM part of the module is SLEEP mode, the following method can wake up the module

- Enable DTR pin to wake up the GSM part of the module
If DTR pin is pull down to a low level, this signal will wake up the GSM part of the module from power saving mode. The serial port will be active after DTR changed to low level for

about 40ms.

- Receiving a voice or data call from network to wake up the GSM part of the module
- Receiving a SMS from network to wake up the GSM part of the module
- RTC alarm expired to wake up the GSM part of the module

Note: DTR pin should be held low level during communicating between the module and DTE.

3.7 Summary of state transitions (except SLEEP mode)

Table 12: Summary of state transitions

Further mode	POWER DOWN	Normal mode	Ghost mode (Charge-only mode)	Charging in normal	Alarm mode
Current mode					
POWER DOWN		Use PWRKEY	Connect charger to VCHG and connect battery to VBAT	No direct transition, but via “Ghost mode” or “Normal mode”	Switch on from POWER DOWN mode by RTC
Normal mode	AT+CPOWD or use PWRKEY pin		Connect charger to VCHG and connect battery to VBAT, then switch off module by AT+CPOWD or using PWRKEY	Connect charger to VCHG pin of module and connect battery to VBAT pin of module	Set alarm by “AT+CALARM”, and then switch off the module. When the timer expires, the module turns on and enters Alarm mode
Ghost mode (Charge-only mode)	Disconnect charger	No direct transition, but via “Charging in normal” mode		Turn on the module using PWRKEY OR SET AT Command “AT+CFUN=1”	Set alarm by “AT+CALARM”, when the timer expire, module will enter Alarm mode

SIM548C Hardware Design

Charging in normal	AT+CPOWD → “Ghost mode”, then disconnect charger	Disconnect the charger	Switch off module by AT+CPOWD or using PWRKEY		No direct transition
Alarm mode	Use PWRKEY pin or wait module switch off automatically	Use AT+CFUN	No transition	Use AT+CFUN let module enter Normal mode, then connect the charger to VCHG pin of module	

3.8 RTC backup

The RTC (Real Time Clock) power supply of module can be provided by an external capacitor or a battery (rechargeable or non-chargeable) through PIN 11 on the board-to-board connector. There is a 10K resistance has been integrated in the GSM part of the module used for limiting current.

You need only a coin-cell battery or a super-cap to PIN 11 to backup power supply for RTC.

Note: The VRTC couldn't be designed to a NC pin in your circuit. You should connect the VRTC pin to a battery or a capacitor.

The following figures show various sample circuits for RTC backup.

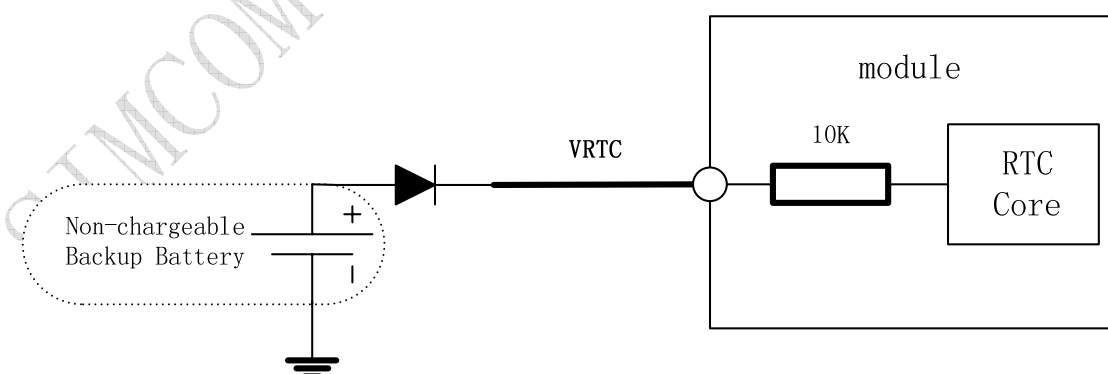

Figure 11: RTC supply from non-chargeable battery

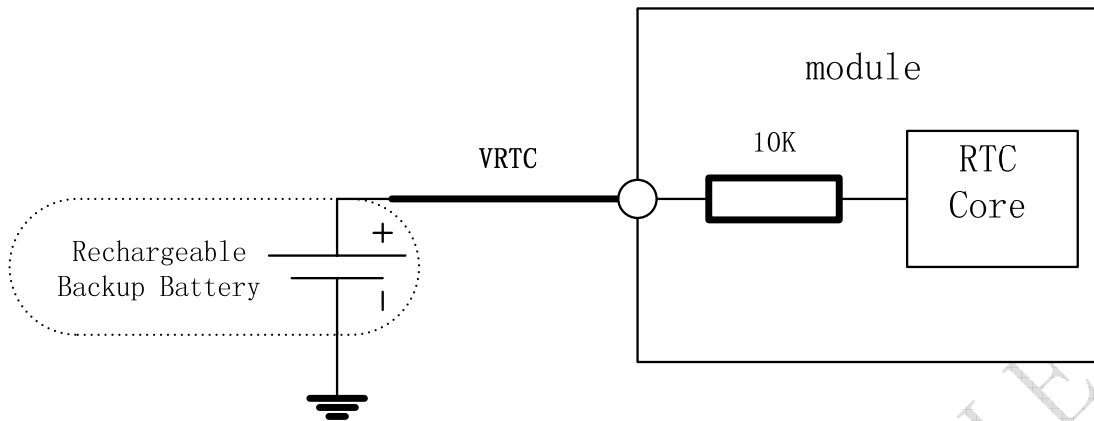

Figure 12: RTC supply from rechargeable battery

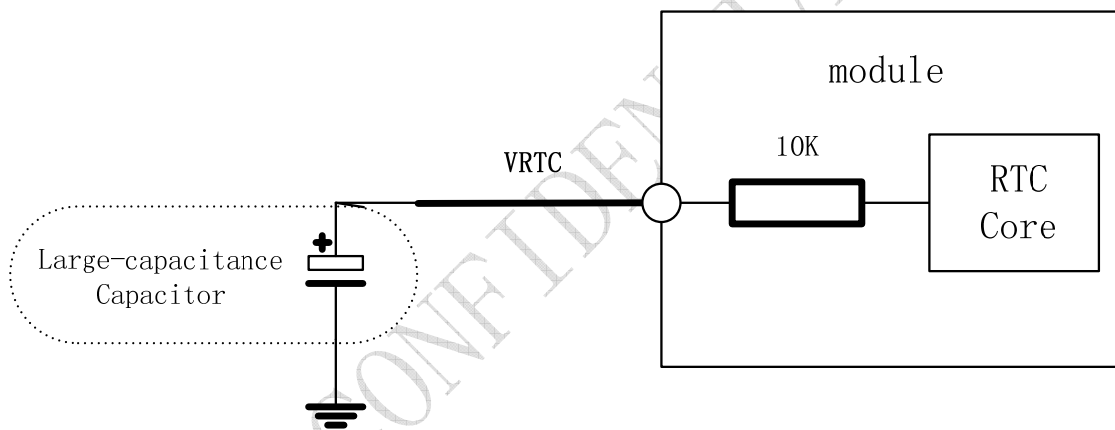

Figure 13: RTC supply from capacitor

- **Li-battery backup**

Rechargeable Lithium coin cells such as the TC614 from Maxell, or the TS621 from Seiko, are also small in size, but have higher capacity than the double layer capacitors resulting in longer backup times.

Typical charge curves for each cell type are shown in following figures. Note that the rechargeable Lithium type coin cells generally come pre-charged from the vendor.

Charger Characteristic

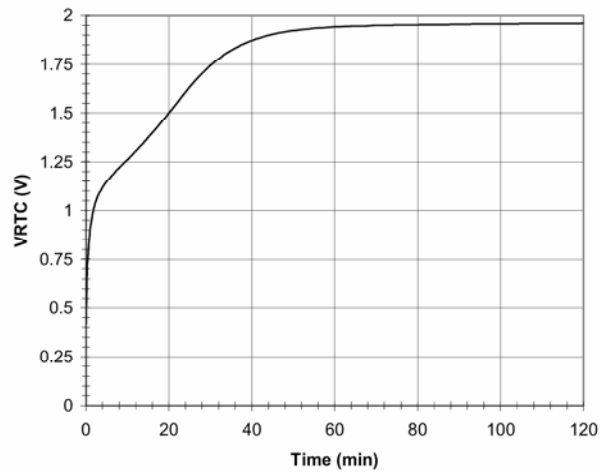

Figure 14: Panasonic EECEMOE204A Charge Characteristic

Charge characteristic

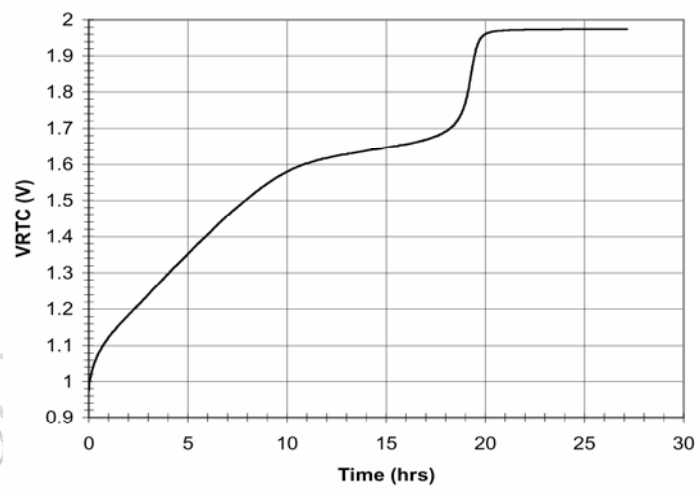

Figure 15: Maxell TC614 Charge Characteristic

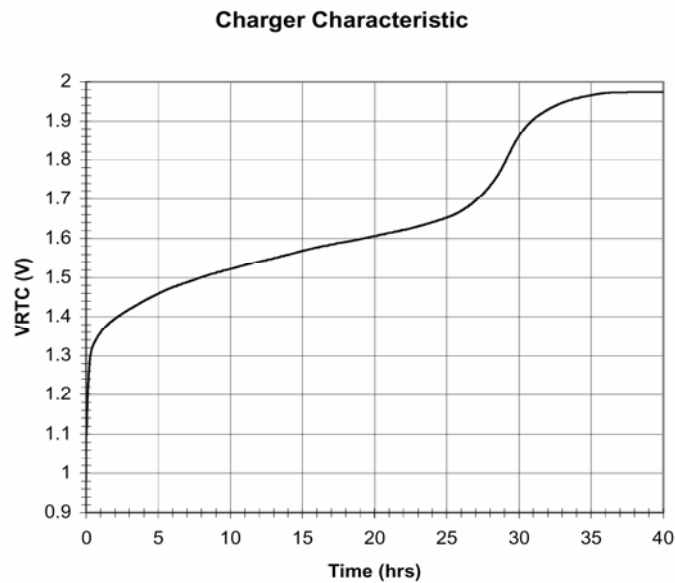

Figure 16: Seiko TS621 Charge Characteristic

Note:

Gold-capacitance backup

Some suitable coin cells are the electric double layer capacitors available from Seiko (XC621), or from Panasonic (EECEM0E204A). They have a small physical size (6.8mm diameter) and a nominal capacity of 0.2F to 0.3F, giving hours of backup time.

3.9 GSM Serial interface

Table 13: Pin definition of the serial interfaces

	Name	Pin	Function
Serial port	DCD	25	Data carrier detection
	DTR	27	Data terminal ready
	RXD	29	Receive data
	TXD	31	Transmit data
	RTS	33	Request to send
	CTS	35	Clear to send
	RI	37	Ring indicator
Debug port	DBG_RXD	36	Receive data
	DBG_TXD	38	Transmit data

The GSM part of the module provides two unbalanced asynchronous serial ports. One is the serial port and another is the debug port. The GSM part is designed as a DCE (Data Communication Equipment), following the traditional DCE-DTE (Data Terminal Equipment) connection. The module and the client (DTE) are connected through the following signal (as following figure shows). Autobauding supports baud rate from 4800bps to 115200bps.

Serial port

- TXD: Send data to the RXD signal line of the DTE
- RXD: Receive data from the TXD signal line of the DTE

Debug port

- DBG_TXD: Send data to the /RXD signal line of the DTE
- DBG_RXD: Receive data from the /TXD signal line of the DTE

The logic levels are described in following table

Table 14: Logic levels of serial ports pins

Parameter	Min	Max	Unit
V_{IL}	0	0.9	V
V_{IH}	2.1	3.3	V
V_{OL}	GND	0.2	V
V_{OH}	2.8	3	V

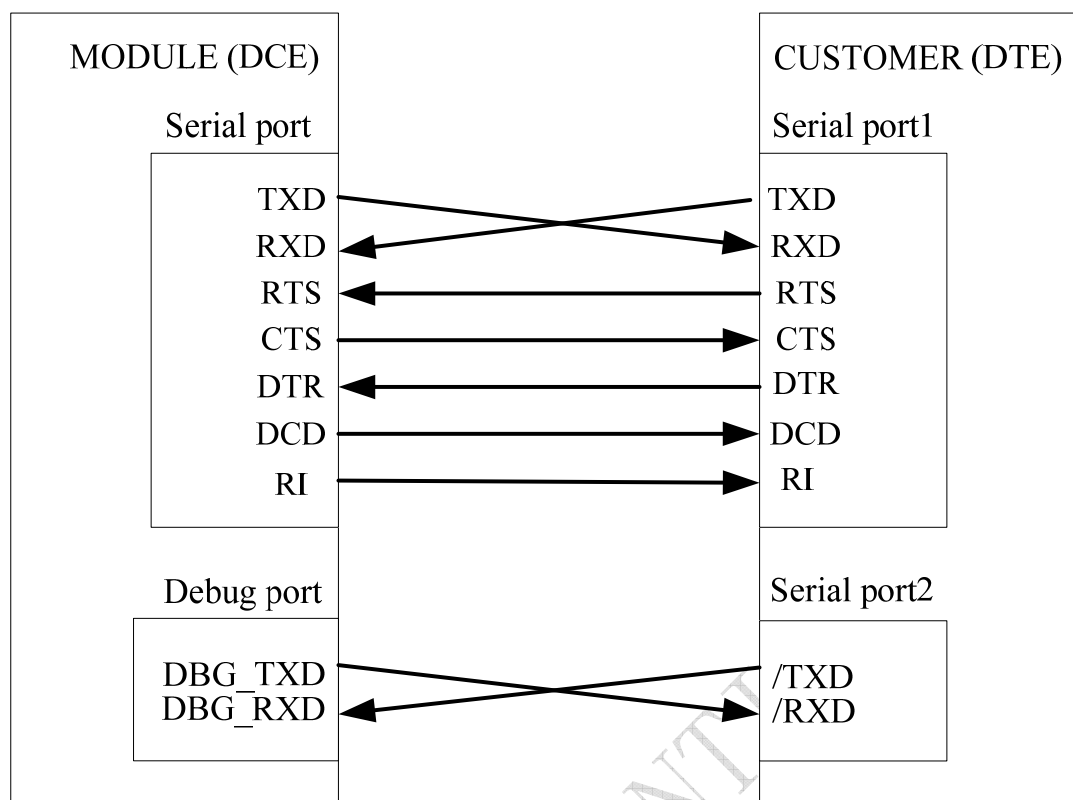

Figure 17: Connection of the serial interfaces

Note: The RTS PIN must be connected to the GND in the customer circuit when only the TXD and RXD are used in the Serial Port communication.

3.9.1 Function of serial port & debug port supporting

Serial port

- Seven lines on serial port.
- Contains data lines TXD and RXD, State lines RTS and CTS, Control lines DTR, DCD and RI.
- Serial port can be used for CSD FAX, GPRS service and send AT command of controlling module. Supports only basic mode of multiplexing so far.
- Serial port supports the communication rates as following:
300, 1200, 2400, 4800, 9600, 19200, 38400, 57600, 115200 Default as 115200bps.
- Autobauding supports baud rates as following:
4800, 9600, 19200, 38400, 57600 and 115200bps.

Autobauding allows the GSM engine to automatically detect the baud rate configured in the host application. The serial port of the GSM engine supports autobauding for the following baud rates: 4800, 9600, 19200, 38400, 57600, 115200bps. Factory setting is autobauding enabled. This gives you the flexibility to put the GSM engine into operation no matter what baud rate your host application is configured to. To take advantage of autobauding mode, specific attention should be

paid to the following requirements:

Synchronization between DTE and DCE.

When DCE powers on with the autobauding enabled, it is recommended to wait 2 to 3 seconds before sending the first AT character. After receiving the “OK” response, DTE and DCE are correctly synchronized.

Restrictions on autobauding operation

- The serial port has to be operated at 8 data bits, no parity and 1 stop bit (factory setting).
- The Unsolicited Result Codes like "RDY", "+CFUN: 1" and "+CPIN: READY" are not indicated when you start up the ME while autobauding is enabled. This is due to the fact that the new baud rate is not detected unless DTE and DCE are correctly synchronized as described above.

Note: You can use AT+IPR=x;&W to set a fixed baud rate and save the configuration to non-volatile flash memory. After the configuration is saved as fixed baud rate, the Unsolicited Result Codes like "RDY" should be received from the serial port all the time that GSM part of the module is power on.

Debug port

- Two lines on Debug port
- Only contains Data lines /TXD and /RXD
- Debug Port only used for debugging. It cannot be used for CSD call, FAX call. And the Debug port can not use multiplexing function. It doesnot support autobauding function.;
- Debug port supports the communication rate as following:
9600, 19200, 38400, 57600, 115200bps(default)

3.9.2 Software upgrade and software debug

The TXD、RXD、DBG_TXD、DBG_RXD、GND must be connected to the IO connector when user need to upgrade software and debug software, the TXD、RXD should be used for software upgrade and the DBG_TXD、DBG_RXD for software debugging. The PWRKEY pin is recommended to connect to the IO connector. The user also can add a switch between the PWRKEY and the GND. The PWRKEY should be connected to the GND when the module is upgrading software. Please refer to the following figures.

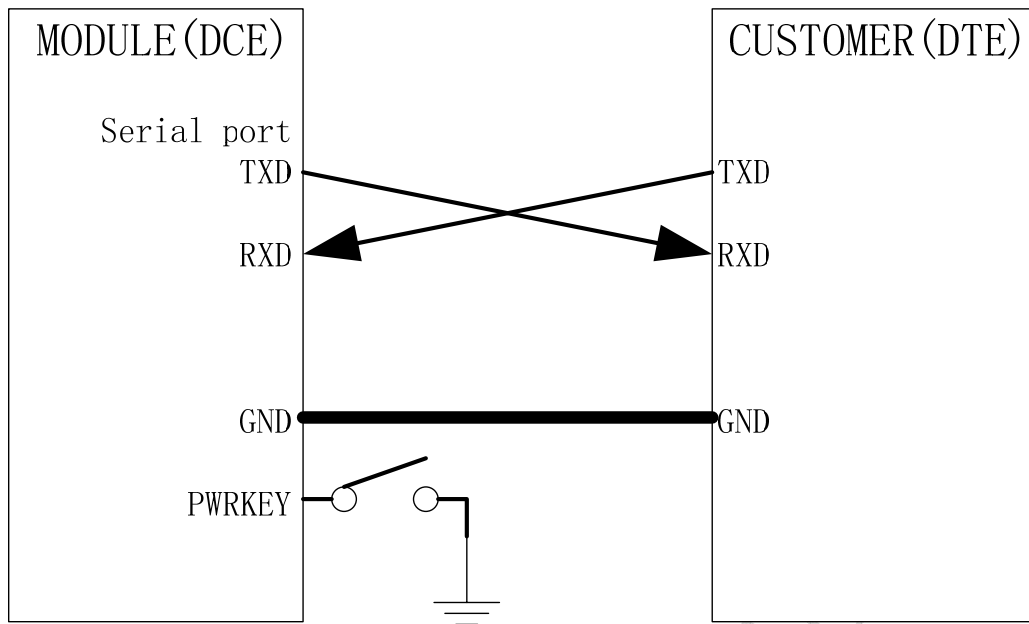

Figure 18: Connection of software upgrade

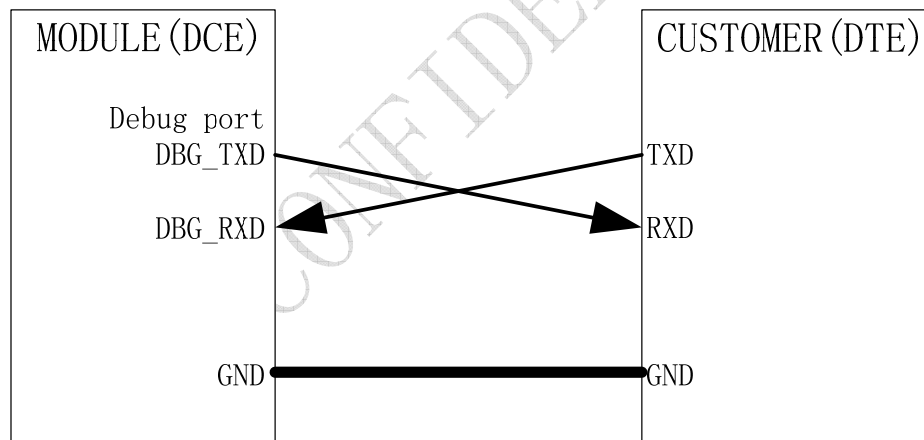

Figure 19: Connection of software debug

The serial port and the debug port don't support the RS232 level and it only supports the CMOS level. Please refer to the table of Logic levels of serial ports pins for details about the voltage level. You should add the level converter IC between the DCE and DTE. If you connect it to the computer. Please refer to the following figure.

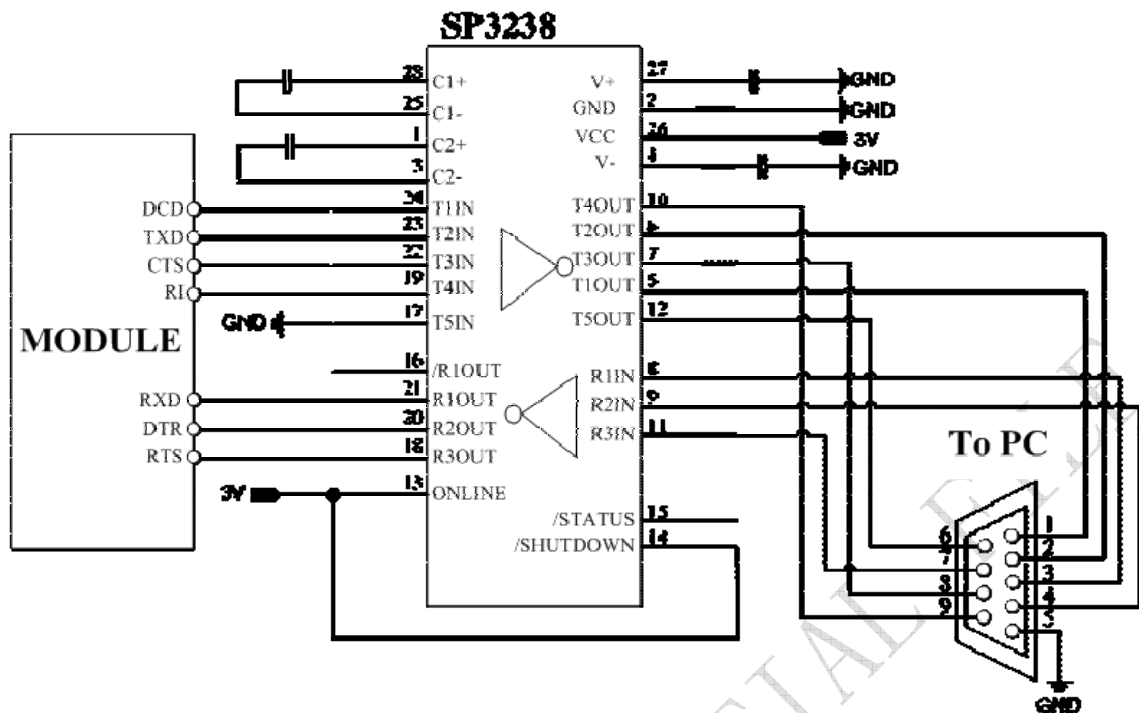

Figure 20: RS232 level converter circuit

Note : For detail information about serial port application, please refer to document [12]

3.10 Audio interfaces

Table 15: Pin definition of the Audio interface

	Name	Pin	Function
(AIN1/AOUT1)	MIC1P	42	Microphone1 input +
	MIC1N	44	Microphone1 input -
	SPK1P	41	Audio1 output+
	SPK1N	43	Audio1 output-
(AIN2/AOUT2)	MIC2P	46	Microphone2 input +
	MIC2N	48	Microphone2 input -
	SPK2P	45	Audio2 output+
	SPK2N	47	Audio2 output-

The module provides two analog input channels, AIN1 and AIN2, which may be used for both microphone and line inputs. The electret microphone is recommended when the interface is used

SIM548C Hardware Design

for microphone. One of the two channels is typically used with a microphone built into a handset. The other channel is typically used with an external microphone or external line input. The module analog input configuration is determined by control register settings and established using analog multiplexers.

For each channels, you can use AT+CMIC to set the input gain level of microphone, use AT+SIDET to set the side-tone level. In addition, you can also use AT+CLVL to adjust the output gain level of both receiver and speaker at the same time, use AT+CHFA to activate one of the two audio channels and deactivate the other one.. For more details, please refer to *document [1]*.

Note: Use AT command AT+CHFA to select audio channel:

0— AIN1/AOUT1 (normal audio channel), the default value is 0.

1— AIN2/AOUT2(aux audio channel) .

It is suggested that you adopt the one of the following two matching circuits in order to improve audio performance. The difference audio signals have to be layout according to difference signal layout rules. As show in following figures (**Note: all components package are 0603.**) If you want to adopt an amplifier circuit for audio, we recommend National company's LM4890. Of course you can select it according to your requirement.

Note : The GND and AGND should not be connected outside the module.

3.10.1 Speaker interface configuration

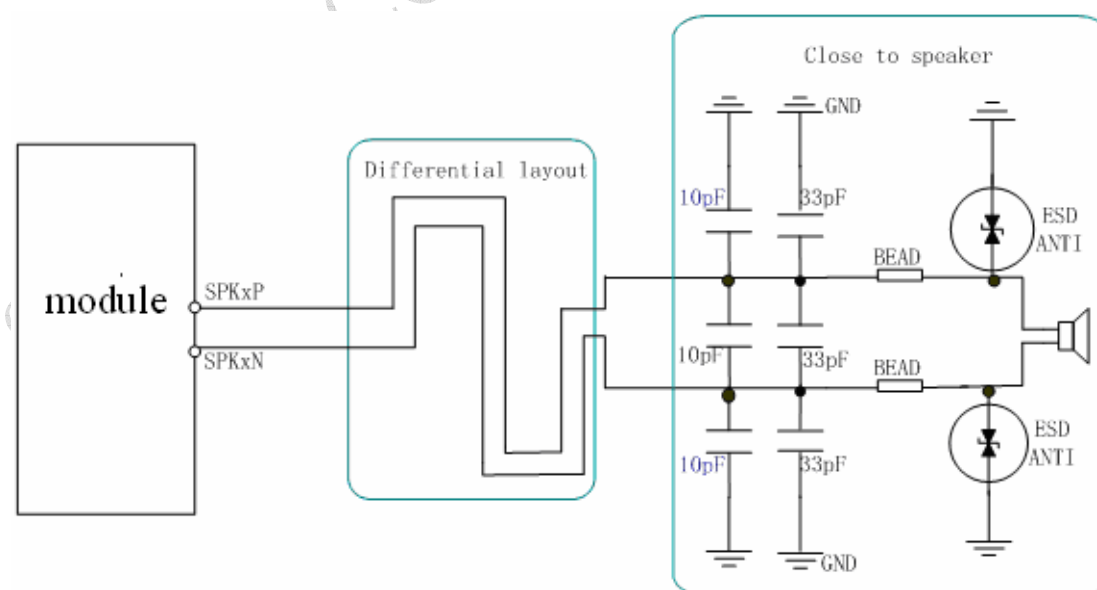

Figure 21: Speaker interface configuration

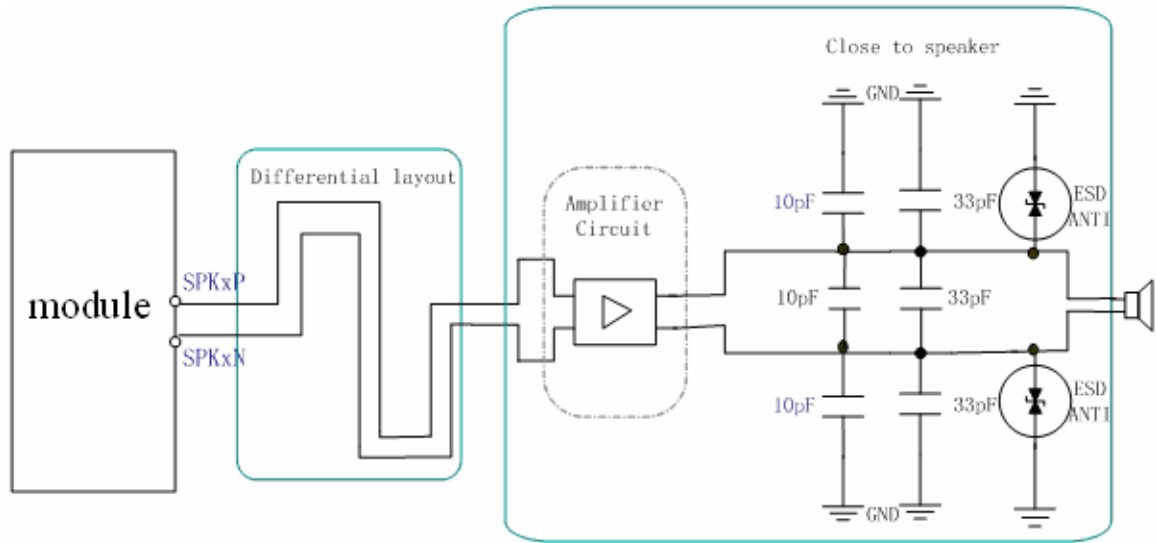

Figure 22: Speaker interface with amplifier configuration

3.10.2 Microphone interfaces configuration

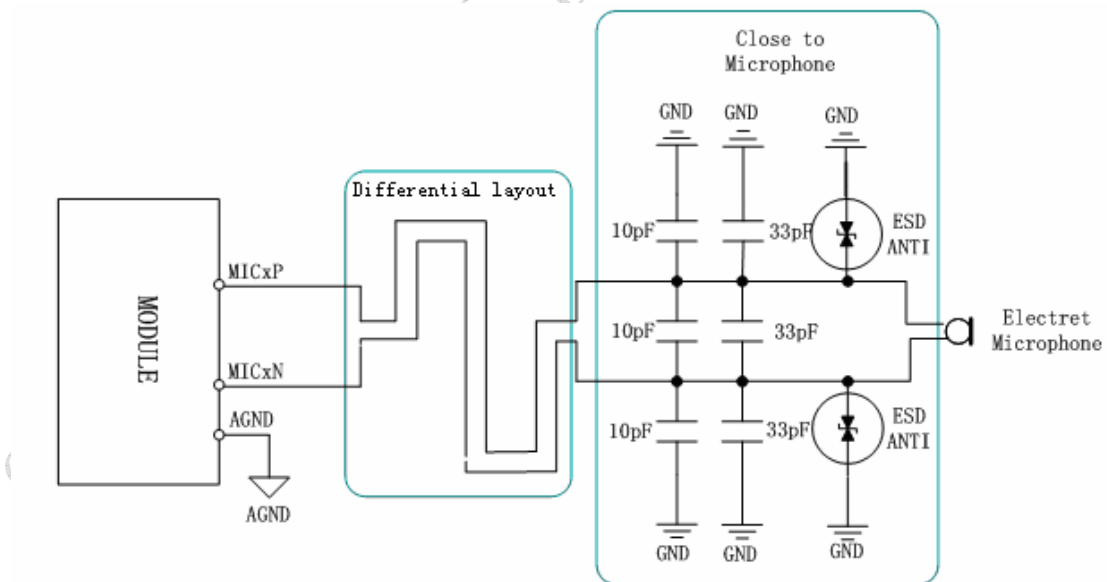

Figure 23: Microphone interface configuration

3.10.3 Earphone interface configuration

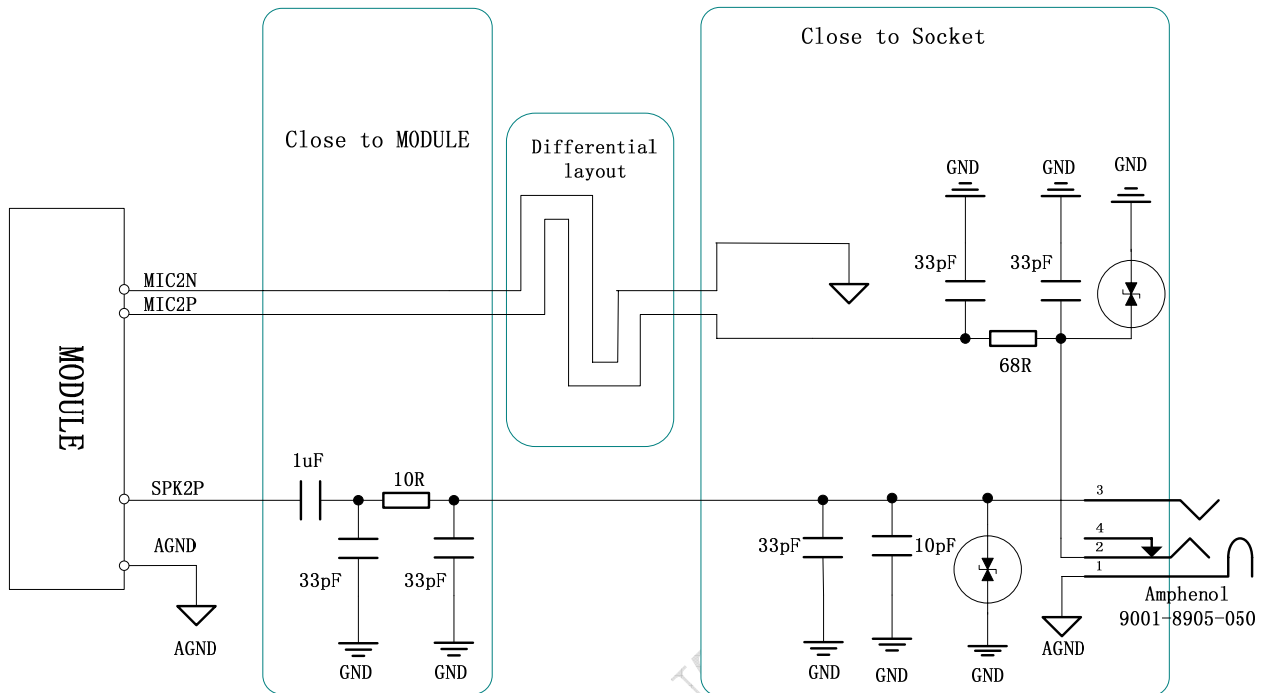

Figure 24: Earphone interface configuration

3.10.4 Referenced electronic characteristic

Table 16: MIC Input Characteristics

Parameter	Min	Typ	Max	Unit
Working Voltage	1.2	1.5	2.0	V
Working Current	200		500	uA
External Microphone Load Resistance	1.2	2.2		k Ohms

Table 17: SPK Output Characteristics

Parameter	Min	Typ	Max	Unit
-----------	-----	-----	-----	------

SIM548C Hardware Design

Normal Output(SPK1)	Single Ended	load Resistance	27	32		Ohm
		Ref level		0.5477 -12.04		Vpp dBm
	Differential	load Resistance	27	32		Ohm
		Ref level		1.0954 -6.02		Vpp dBm
Auxiliary Output(SPK2)	Single Ended	load Resistance	27	32		Ohm
		Ref level		0.5477 -12.04		Vpp dBm
	Differential	load Resistance	27	32		Ohm
		Ref level		1.0954 -6.02		Vpp dBm

3.11 SIM interface

3.11.1 SIM card application

You can use AT Command to get information in SIM card. For more information, please refer to *document [1]*.

The SIM interface supports the functionality of the GSM Phase 1 specification and also supports the functionality of the new GSM Phase 2+ specification for FAST 64 kbps SIM (intended for use with a SIM application Tool-kit).

Both 1.8V and 3.0V SIM Cards are supported.

The SIM interface is powered from an internal regulator in the module having normal voltage 3V.

All pins reset as outputs driving low. Logic levels are as described in table18

Beside the SIM interface pin, there are also a SIM card holder in the module. The customer can use either the SIM card holder in the module or the SIM interface pin.

Table 18: Pin definition of SIM interface (board-to-board connector)

Pin	Signal	Description
17	SIM_VDD	SIM Card Power supply, it can identify automatically the SIM Card power mode, one is 3.0V±10%, another is 1.8V±10%. Current is about 10mA.
19	SIM_RST	SIM Card Reset
21	SIM_DATA	SIM Card data I/O
23	SIM_CLK	SIM Card Clock
15	SIM_PRESENCE	SIM Card Detection

Following is the reference circuit about SIM interface. We recommend an Electro-Static discharge device ST (www.st.com) ESDA6V1W5 or ON SEMI (www.onsemi.com) SMF05C for “ESD ANTI”.

The SIM_PRESENCE pin is used for detecting the SIM card removal. You can use the AT command “AT+CSDT” to set the SIMCARD configuration. For detail of this AT command, please refer to *document [1]*:

You can select the 8-pins SIM card holder. The reference circuit about 8 pins SIM card holder illustrates as following figure.

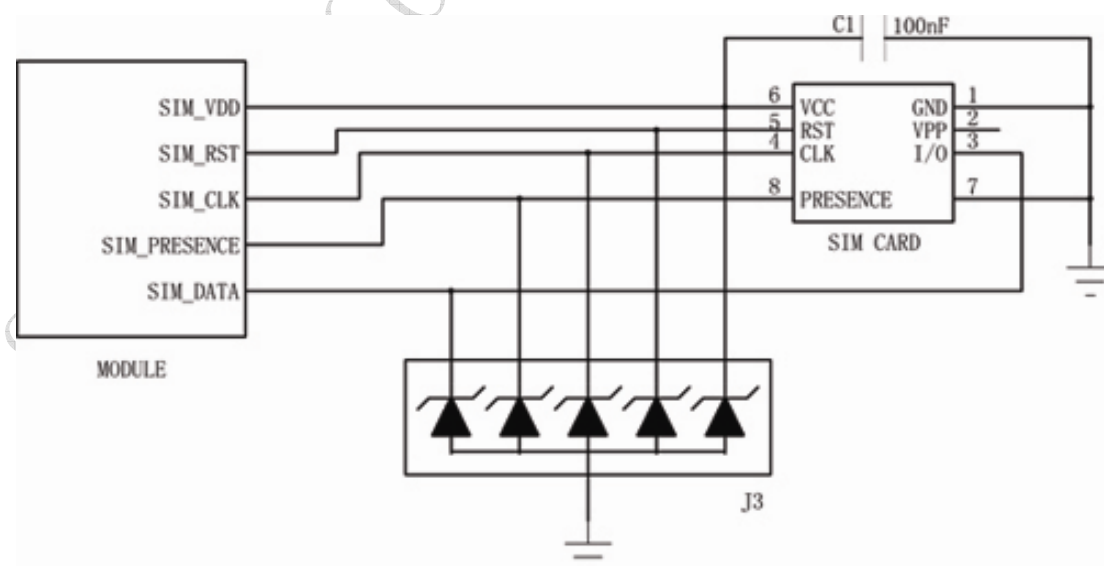
**Figure 25: SIM interface reference circuit with 8-pin SIM card**

If you don't use the SIM card detection function, you can let the SIM_PRESENCE pin, connect to

the GND. The reference circuit about 6 pins SIM card illustrate as following figure.

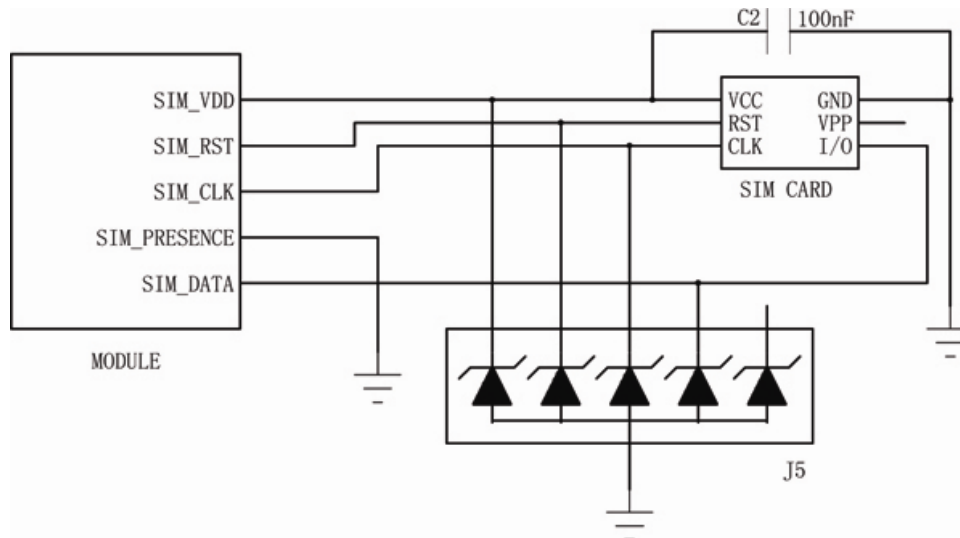

Figure 26: SIM interface reference circuit with 6-pin SIM card

3.11.2 Design considerations for SIM card holder

For 6-pin SIM card holder, we recommend to use Amphenol C707-10M006 512 2 . You can visit <http://www.amphenol.com> for more information about the holder.

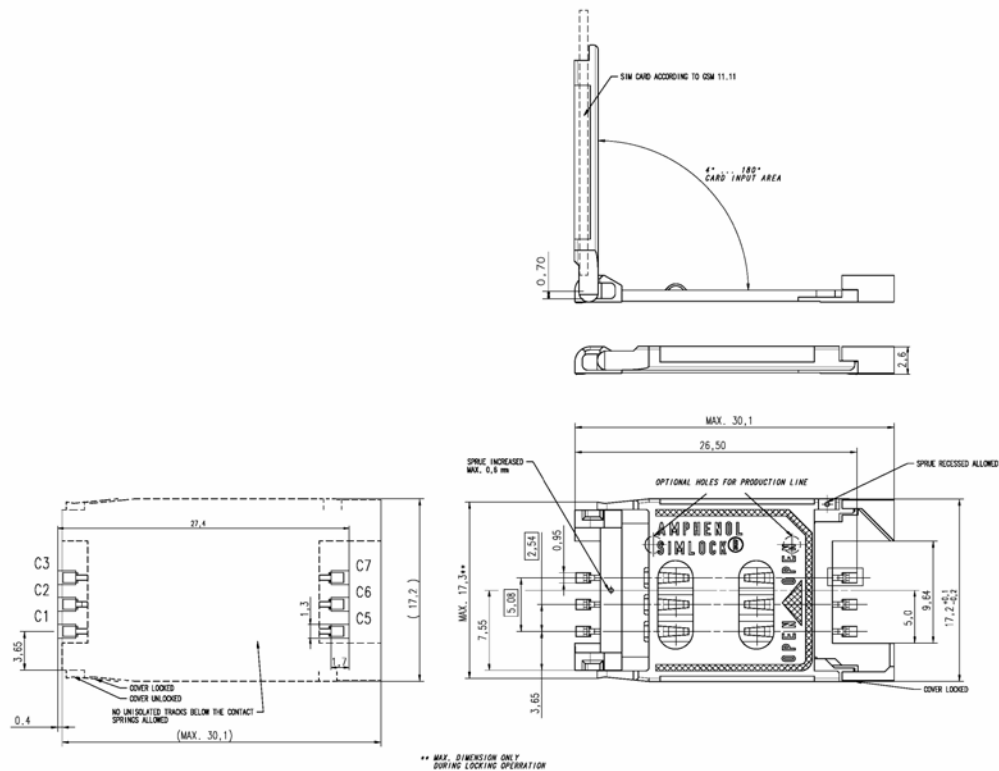

Figure 27: Amphenol C707-10M006 512 2 SIM card holder

Table 19: Pin definition (Amphenol SIM card holder)

Pin	Signal	Description
C1	SIM_VDD	SIM Card Power supply, it can identify automatically the SIM Card power mode, one is 3.0V±10%, another is 1.8V±10%. Current is about 10mA.
C2	SIM_RST	SIM Card Reset.
C3	SIM_CLK	SIM Card Clock.
C5	GND	Connect to GND.
C6	VPP	Not connect.
C7	SIM_DATA	SIM Card data I/O.

For 8-pin SIM card holder, we recommend to use Molex 91228. You can visit <http://www.molex.com> for more information about the holder.

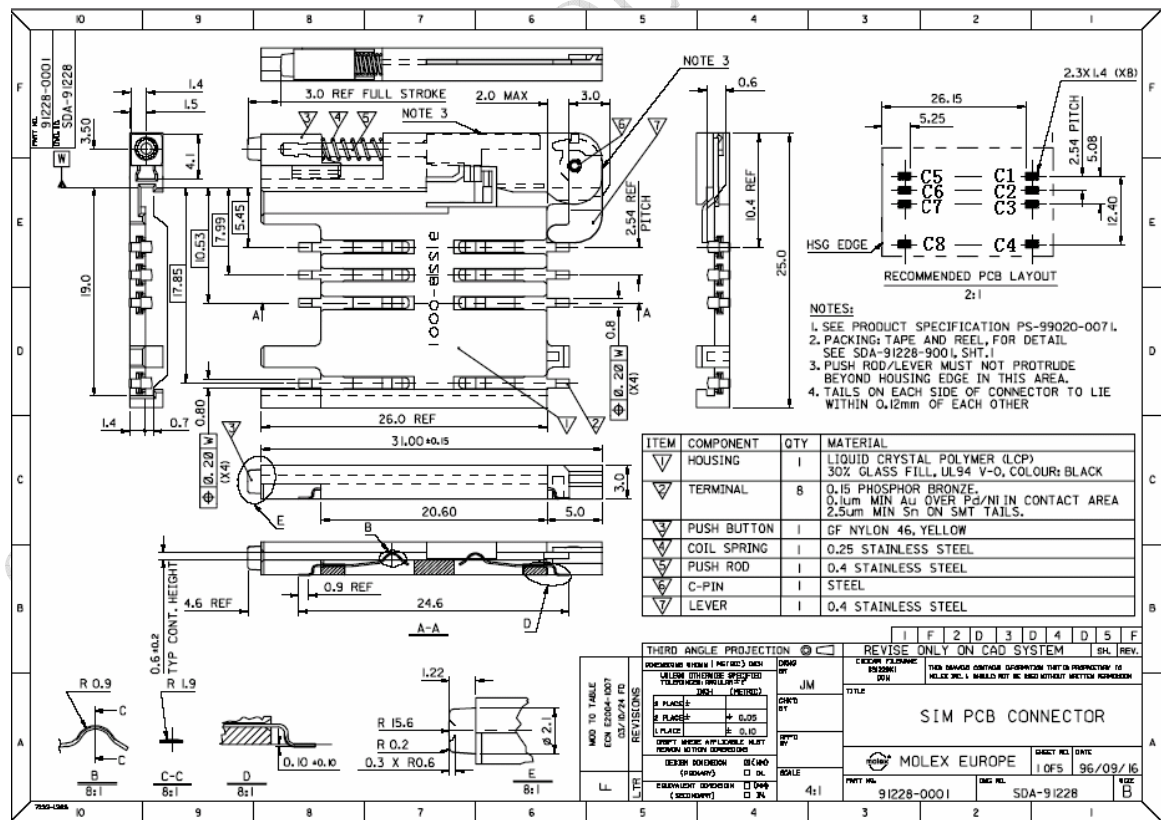

Figure 28: Molex 91228 SIM card holder

Table 20: Pin definition (Molex SIM card holder)

Pin	Signal	Description
C1	SIM_VDD	SIM Card Power supply, it can identify automatically the SIM Card power mode, one is 3.0V±10%, another is 1.8V±10%. Current is about 10mA.
C2	SIM_RST	SIM Card Reset.
C3	SIM_CLK	SIM Card Clock.
C4	GND	Connect to GND.
C5	GND	Connect to GND.
C6	VPP	Not connect.
C7	SIM_DATA	SIM Card data I/O.
C8	SIM_PRESENCE	Detect SIM Card Presence

3.12 LCD interface

The GSM part of the module provides a serial LCD display interface that supports serial communication with LCD device. These are composite pins that can be used as GPIO ports or LCD display interface according to your application. When use as LCD interface, the following table is the pin description. LCD interface timing should be united with the LCD device.

Table 21: Pin definition of the LCD interface

Name	Pin	Function
DISP_DATA	28	Display data output
DISP_CLK	26	Display clock for LCD
DISP_CS	24	Display enable
DISP_D/C	30	Display data or command select
DISP_RST	32	LCD reset

Note: This function is not supported in the default firmware. There must be some special firmware if you want. Please contact SIMCom for more details.

3.13 ADC

The GSM part of the module provide two auxiliary ADC (General purpose analog to digital converter.) as voltage input pin, which can be used to detect the values of some external items such as voltage、 temperature etc. User can use AT command “AT+RADC” to read the voltage value added on ADC0 pin. For detail of this AT command, please refer to *document [1]*.

Table 22: ADC specification

	Min	Typ	Max	Units
Voltage range	0		2.4	V
ADC Resolution	16		16	bits
ADC accuracy(1)		0.59		mV
Sampling rate		5		Sec

(1): ADC accuracy 12bits.

3.14 General purpose input & output(GPIO)

Table 23: Pin description of the GPIO interface

Pin	Name	Function
34	GPIO0	General Purpose Input/Output Port
22	GPIO1	General Purpose Input/Output Port

Note: This function is not supported in the default firmware. There must be special firmware if you require. Please contact SIMCom for more details .

3.15 Behaviors of the RI line (serial port1 interface only)

Table 24: Behaviours of the RI line

State	RI respond
Standby	HIGH

SIM548C Hardware Design

Voice calling	Change LOW, then: (1) Change to HIGH when establish calling. (2) Use AT command ATH the RI pin changes to HIGH.. (3) Sender hang up, change to HIGH (4) Change to HIGH when SMS received.
Data calling	Change LOW, then: (1) Change to HIGH when establish calling. (2) Use AT command ATH the RI changes to HIGH.
SMS	When receive SMS, The RI will change to LOW and hold low level about 120ms, then change to HIGH.
URC	Some URCs triggers 120ms low level on RI. For more details, <i>please refer to document [12]</i>

If the module is used as caller, the RI on the board-to-board connector. However when it is used as receiver, following is timing of RI.

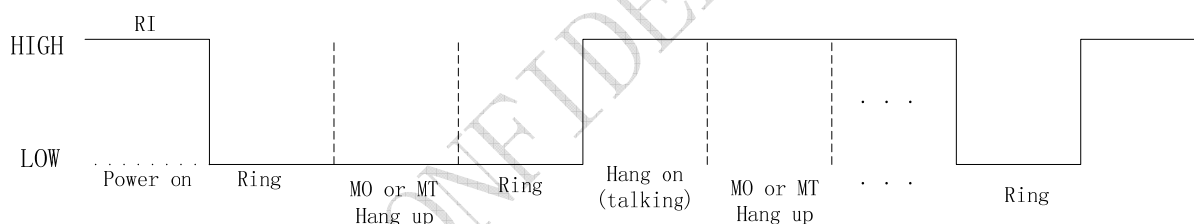

Figure 29: The GSM part Services as Receiver

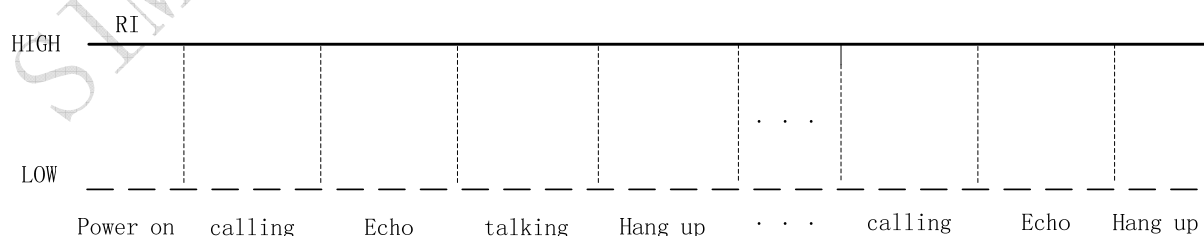

Figure 30: The GSM part Services as caller

3.16 Network status indication

The NETLIGHT on the board-to-board connector can be used to drive a network status indication LED lamp. The working state of this pin is listed in table;

Table 25: Working state of the NETLIGHT

State	The GSM part of SIM548C function
Off	The GSM part of the module is not running
64ms On/ 800ms Off	The GSM part of the module does not find the network
64ms On/ 3000ms Off	The GSM part of the module find the network
64ms On/ 300ms Off	GPRS communication

We provide a reference circuitry for you, shown as the following figure:

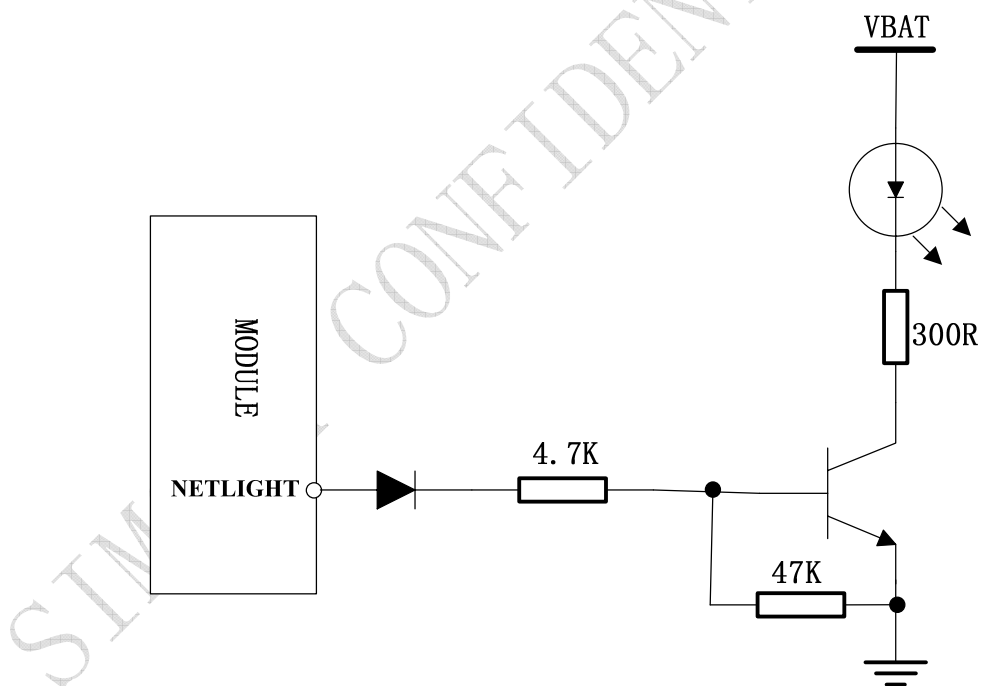

Figure 31: Reference circuit of NETLIGHT

3.17 Buzzer

The BUZZER on the board-to-board connector can be used to drive a buzzer to indicate incoming call. The output volume of buzzer can be set by “AT+CRSL”. The reference circuit for buzzer

shown as following figure:

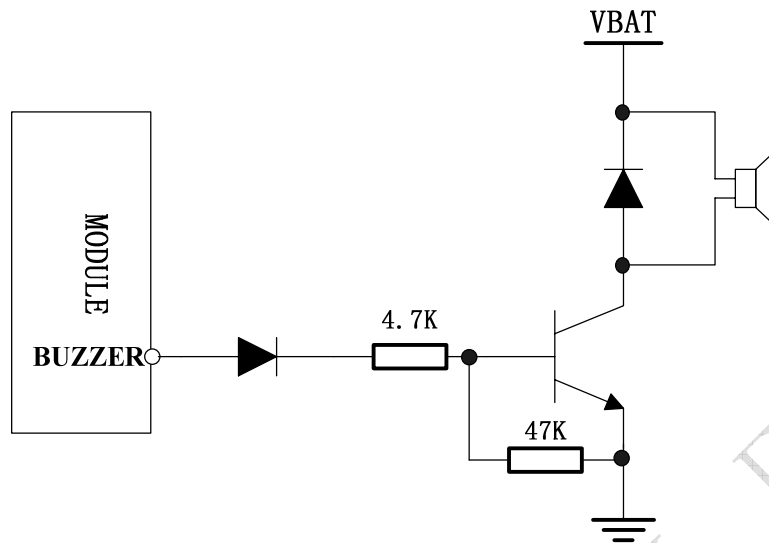

Figure 32: Reference circuit of Buzzer

Table 26: Buzzer Output Characteristics

Parameter	Min	Typ	Max	Unit
Working Voltage	2.4	2.8	3.3	V
Working Current		2		mA
Load Resistance	1			k Ohms

4 GPS application interface

A GPS receiver with high performance has been integrated to offer GPS full function, it continuously tracks all satellites in view and provides accurate satellite position data. Otherwise, the GPS part can run separately even while the GSM part of SIM548C has been deregistered from the GSM network.

4.1 Theory of operation

The theory of operation is shown in the following figure:

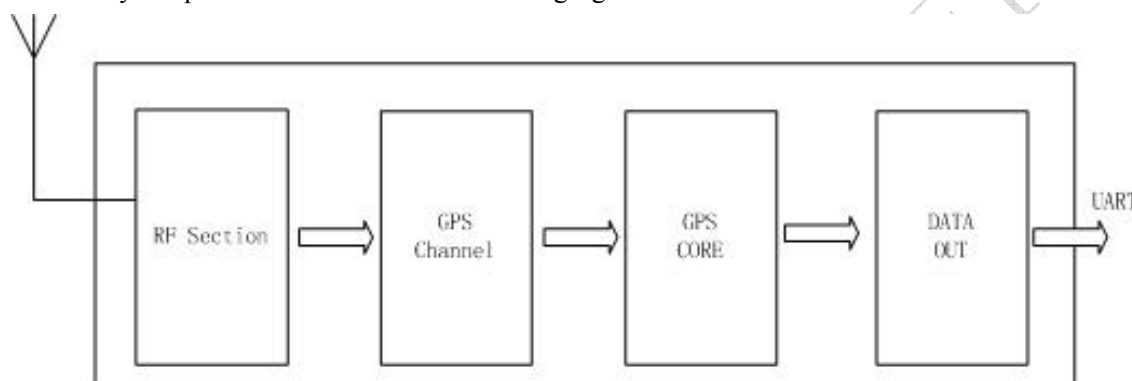

Figure 33: Theory of operation

The Module's GPS part is designed to use L1 Frequency (C/A Code) GPS receiver and performs the entire GPS signal processing, from antenna input to serial position data output.

The processing steps involved are:

RF section

In the RF section the GPS signal detected by the antenna is amplified, filtered and converted to an intermediate frequency (IF). An A/D converter converts the analogue intermediate frequency into a digital IF signal.

GPS channels

The received digital IF signal bit stream is passed to the baseband section, where it is fed into the correlators. The function of the correlators are to acquire and track the satellite signals. There are 12 channels used in parallel, with each correlator looking for a characteristic PRN code sequence in the bit stream. Once the correlator has found a valid signal, pseudo range, carrier phase and orbit information can be extracted from the GPS signal.

GPS CORE

The on-board processor is running an algorithm that calculates the position, velocity and time. This calculation is called navigation solution. Once the navigation solution is calculated, it can be transformed into the desired coordinate system, e.g. Latitude/Altitude.

DATA OUT

The data of the navigation solution are available at the serial RS-232 interface.

4.2 Technical data

Power consumption

180mW with active antenna (continuous mode),

150mw with Passive antenna (continuous mode)

Push-to-Fix reduces power by as much as 98%

Note: The operation of Push-to-Fix mode please refer to document[2].

Protocols

SiRF binary/NMEA-0183

AI3/F (SiRF Interface) for AGPS

RTCM (for DGPS)

Position accuracy

Autonomous: < 10m

SBAS (WASS, EGNOS: < 5m)

Beacon DGPS: < 3m

Receiver

Tracking: L1, C/A code

Channels: 20

Update rate: Default 1 Hz

Tracking Sensitivity: -157 ± 2 dBm (refer to note)

Max. Altitude: <60.000 ft (18,000 m)

Max. velocity: <1.000 knots (515 m/s)

Protocol support: NMEA-0183, SiRF binary

Acquisition rate

Standalone

Hotstart: < 1 seconds, open sky

Warmstart: < 38 seconds, open sky

Coldstart: < 42 seconds, open sky

AGPS

GSM: <1s, open sky

GSM: <24s, indoor

Note:

1) The receiver sensitivity above-mentioned is mostly related to antenna reference point, such as the antenna type, the antenna amplifier, the customer application or the placement and the applied reference setup and so on.

2) AGPS: This function needs more supporting form the mobile telecommunication network. AGPS support, based on the AGPS firmware. Now the standard version of the firmware in the module does not support AGPS.

4.3 Pin description

Table 27: Pin definition

Power Supply			
PIN NAME	I/O	DESCRIPTION	
GPS_VCC	I	GPS_VCC pins of the board-to-board connector are dedicated to connect the supply voltage. The power supply for GPS whole part has to be a single voltage source It must be able to provide sufficient current of >150mA in the procedure of tracking satellites	Vmax= 5.0V Vmin=3V Vnorm=3.3V
GPS_VRTC	I	Apply 3V dc for backup RTC & SRAM. If unused, leave it open.	Vmax= 3.3V Vmin=2.7V Vnorm=3.0V

SIM548C Hardware Design

GPS_VANT	I	The external DC power supply for an active GPS antenna. It's input voltage depends on the type of chosen active antenna, for the 5V type, it has to be connected to 5V external power supply; for the 3V type, it can be connected to the GPS_VCC_RF pin directly which provides 2.85V DC.	Imax=25mA Vmax=5V Vmin=2.85V
GPS_VCC_RF	O	The optional power supply for 3.0V type active antenna.	Vmax=2.9V Vmin=2.8V Vnorm=2.85V Imax=25mA
GND		Ground, shared with GSM part	
Dual serial interface			
PIN NAME	I/O	DESCRIPTION	DC CHARACTERISTICS
GPS_TXA	O	Serial data output for port A	VILmin=-0.3V
GPS_RXA	I	Serial data input for port A	VILmax=0.84V
GPS_TXB	O	Serial data output for port B	VIHmin=1.96V
GPS_RXB	I	Serial data input for port B	VIHmax= 3.1
			VOLmin=GND
			VOLmax=0.7V
			VOHmin=2.1V
			VOHmax=2.8V
Control signals			
PIN NAME	I/O	DESCRIPTION	
GPS_BOOTSEL	I	For re-programming the Flash, it must be set to High	
GPS_M-RST	I	Reset pin, active low. If used, it causes the module to reset; if not used, leave it open .	Note, if this pin is pulled down by a GPIO, then the GPIO must have the capability of inputting 1.5mA current.
GPS_TimeMark	O	1 PPS timemark output for synchronizing to within 1 microsecond of GPS time.	If not used, leave it open.

SIM548C Hardware Design

GPS_WAKEUP	I	It only be used to wakeup the system from PTF mode. If not used, the user must connect this pin to the ground through a 0R resistor.	
------------	---	--	--

Table 28: Consolidated PIN Characteristics

PIN	Default Direction
GPS_TXA	O
GPS_RXA	I
GPS_TXB	O
GPS_RXB	I

4.4 Turn on the GPS part

To turn on the GPS module, the GPS_VCC must be higher than 2.3V, and should be kept on for 220ms at least. The theory of turning on is shown in the following figure:

SIMCOM CONFIDENTIAL

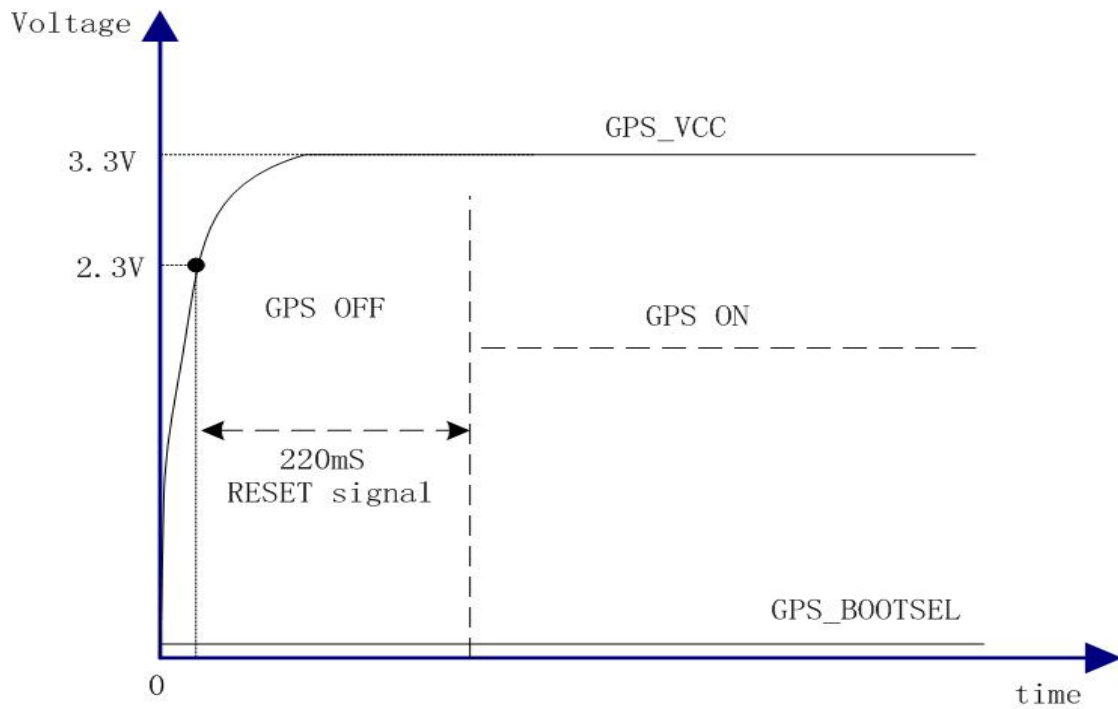

Figure 34: Turn on the GPS module

4.5 The theory of the GPS RTC circuit

The RTC is very important for the GPS module, because the data kept in the SRAM is depended on the VRTC. Please keep the VRTC on if you want to use the function of hotstart, warmstart, or Push-To-Fix mode. There is a RTC LDO in our SIM548C module; it can provide 1.5V voltage to the SRAM. The theory of RTC circuit is shown in the following figure:

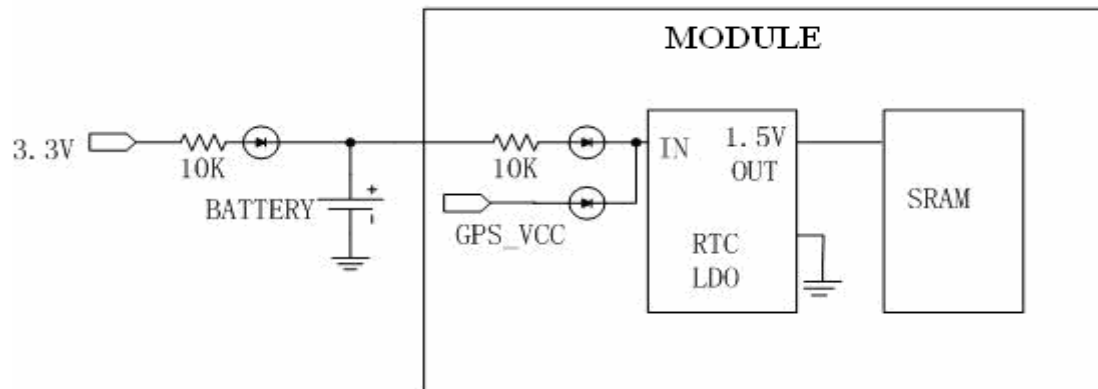

Figure 35: Theory of the GPS RTC circuit

4.6 The theory of the RESET Circuit

There is a RESET IC in the module's GPS part. If the input of the reset IC is lower than 2.3V, the "reset" pin will keep low; then the input voltage is higher than 2.3V, the RESET IC will output a low level voltage for about 220mS as a reset signal. After that the reset output pin will be kept high. So, if the user wants to reset the module's GPS part, the GPS_M-RST should be pulled down longer than 10ms, and then pull it up. The theory of the RESET Circuit is shown in the figure:

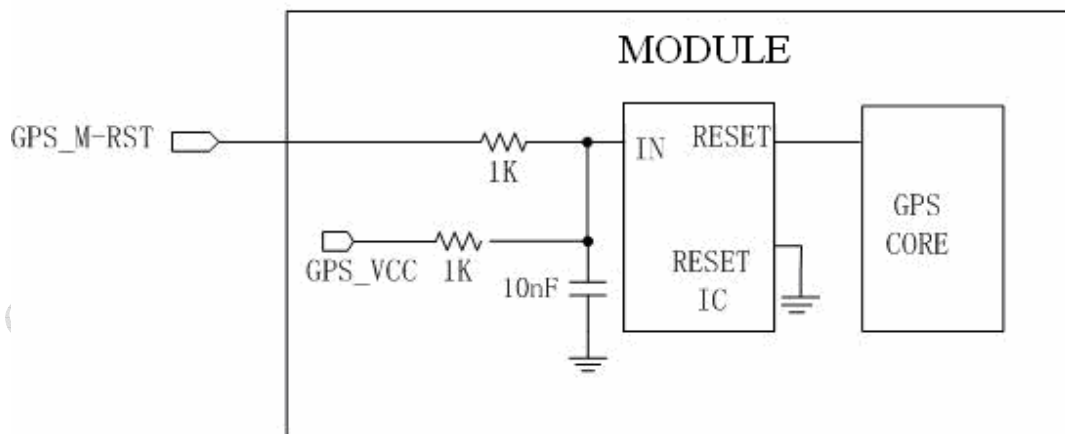

Figure 36: Theory of the RESET circuit

4.7 GPS operation modes

Table 29: GPS operation modes

Mode	Function
Normal operation	The receiver is continuously running in Normal mode, as long as the operating voltage Vcc is supplied. Position fixes are generated at the maximum update rate. This enables the receiver a warm- and hotstart. However, the cold- and warmstart times of receiver do not differ significantly under good visibility conditions.
Power Down mode	In this mode the user can cut off the GPS_VCC to save more power consumption. But the VRTC must always be on. When the user resumes the GPS_VCC, the receiver wakes up, a valid position can be computed in the normal hot-start time.
Push-to-Fix mode (Refer to Note)	In this mode the receiver will turn on every a given minutes (this period can be set form 10 minutes to 2 hours by software) to perform a system update consisting of position, time, ephemeris data refreshing and RTC calibration. When the PTF mode is enabled, upon power on or a new PTF cycle, the receiver will stay on full power until the good navigation solution is computed. The stand-by state will follow for the remainder of the period. For example, if it took 36 seconds to fix position and refresh ephemeris on the default period of 30 minutes, the receiver will sleep for the 29 minutes and 24 seconds. When the application needs a position report, it can toggle the GPS_M-RST pin to wake up the receiver. When the receiver wakes up, a valid position can be computed in the normal hot-start time.

4.8 Serial interface of the GPS part

The GPS part of the module offers two serial interfaces, Allows for different protocols to operate on each port.

For example:

Serial port A

- 2-wire serial interface
- Includes the GPS_RXA (receive) and TXA (transmit) lines
- Supported baud rate: 1200 -115200bps, but 4800 - 38400bps is a common rate range
- Protocol: Default NMEA ,4800bps

SIM548C Hardware Design

- Default output message: GGA,GSA, GSV,RMC,VTG
- Update rate: Default 1Hz
- Datum WGS84 default (User configurable)

Serial port B

- 2-wire serial interface
- Includes the GPS_RXB(receive) and GPS_TXB (transmit) lines
- Supported baud rate: 1200—115200 bps
- Protocol: Default none

Notes:

- 1. Both interfaces are configured as 8 data bits, no parity and 1 stop bit..*
- 2. The serial ports also can be configured to adapt to customer specific applications, such as for DGPS, and so on. More detail please contact with SIMCom ltd.*
- 3. We can also help the user to change the protocol and baud rate of the two serial ports by different firmware. For more detail please contact SIMCom Ltd.*

4.9 Start-up procedure

The start-up strategy of the module's GPS part depends on the last position, current time and ephemeris data, that the receiver has stored the external SRAM memory. There are three different start-up procedures:

4.9.1 Coldstart

The coldstart takes place when the receiver has no knowledge of its last position or time. In this case the GPS RTC has not been running and no valid ephemeris data or almanac data is available (The receiver has never been navigating or no battery backup memory available).

4.9.2 Warmstart

This start-up procedure is performed whenever the receiver is able to use the valid almanac data, and has not in an important manner moved since the last valid position calculation. This procedure starts if the receiver has been shut off for more than 2 hours, but the last position, time and almanac are still acknowledged. This procedure is able to announce the current visible satellites in advance. However, since ephemeris data are not available or cannot longer be used, the receiver has to wait for the ephemeris broadcast to complete.

4.9.3 Hotstart

Hotstart is performed whenever the receiver still has access to valid ephemeris data and exact time. This procedure starts if the receiver has been shut off for less than 2 hours and the GPS RTC has been running during that time. Furthermore, during the previous session, the receiver must have been navigating (to allow it to decode and store ephemeris data). In Hotstart, the receiver can announce in advance the currently visible satellites, and is therefore able to quickly obtain and track the signal. Due to the fact that ephemeris is already known, there is no need to wait for the ephemeris broadcast to complete.

5 Antenna interface

5.1 GSM Antenna

The RF interface has an impedance of 50Ω . To suit the physical design of individual applications the module offers alternatives:

- Recommended approach: antenna connector on the component side of the PCB
- Antenna pad and grounding plane placed on the bottom side.

To minimize the loss on the RF cable, it need be very careful to choose RF cable. We recommend the insertion loss should be meet following requirement:

- GSM850/GSM900<0.5dB
- DCS1800/PCS1900<1.0dB

5.1.1 GSM Antenna connector

The module use MURATA's MM9329-2700 RA1 RF connector on the module side, we recommend user use MURATA's MXTK92XXXXX as matching connector on the application side. Please refer to appendix for detail info about MURATA's MXTK92XXXXX.

5.1.2 GSM Antenna pad

The antenna can be soldered to the pad, or attached via contact springs. To help you to ground the antenna, The module comes with a grounding plane located close to the antenna pad. The antenna pad of the module is shown as the following figure:

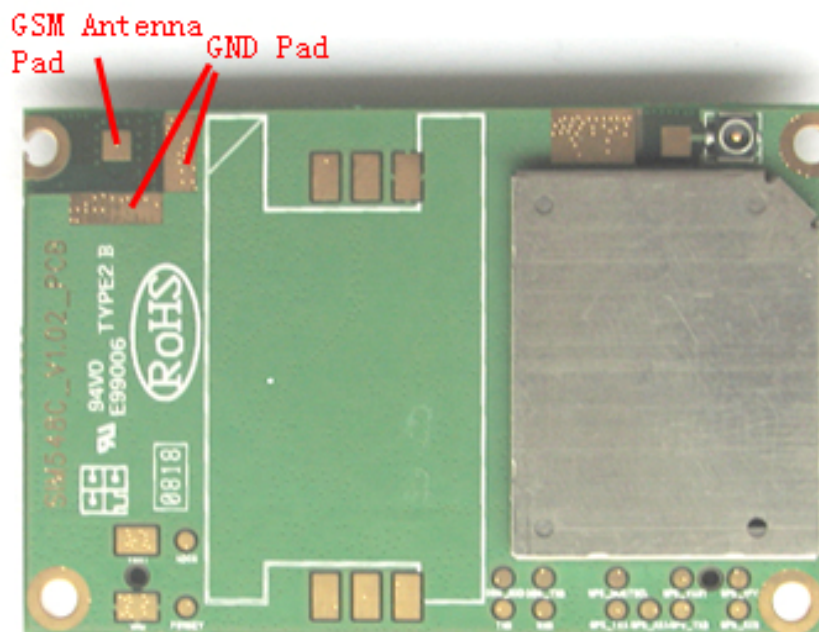
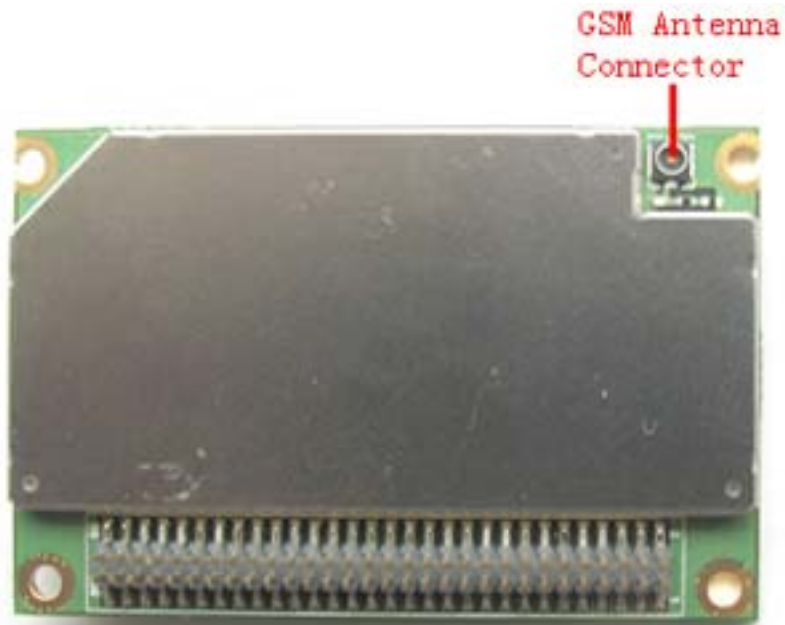

Figure 37: RF connector and RF pad

The GSM part of SIM548C material properties:

PCB Material: FR4

Antenna pad: Gold plated pad

5.1.3 Module RF output power

Table 30: The GSM part conducted RF output power

Frequency	Max	Min
GSM850	33dBm ±2db	5dBm±5db
EGSM900	33dBm ±2db	5dBm±5db
DCS1800	30dBm ±2db	0dBm±5db
PCS1900	30dBm ±2db	0dBm±5db

5.1.4 Module RF receive sensitivity

Table 31: Conducted RF receive sensitivity of the GSM part

Frequency	Receive sensitivity
GSM850	< -106dBm
EGSM900	< -106dBm
DCS1800	< -106dBm
PCS1900	< -106dBm

5.1.5 Module operating frequencies

Table 32: The GSM part operating frequencies

Frequency	Receive	Transmit
GSM850	869 ~ 894MHz	824 ~ 849MHz
EGSM900	925 ~ 960MHz	880 ~ 915MHz
DCS1800	1805 ~ 1880MHz	1710 ~ 1785MHz
PCS1900	1930 ~ 1990MHz	1850 ~ 1910MHz

5.2 GPS Antenna

5.2.1 GPS Antenna Connection

As same as the GSM antenna interface, the module also offer two alternative methods for

customer to install the GPS antenna.

The first method, and which is our recommended method, is installing GPS antenna via a proper Microwave Coaxial Cable and connect to the antenna connector of the module provided. About the connector's type and the matched Microwave Coaxial Cable, please refer to the section 5.1.1.

The second method of installing the GPS antenna is soldering the GPS antenna on the GPS antenna pad of the module provided. The antenna pad's structure is similar to the GSM Antenna pad which is referred in section 5.1.2. The GND pad, which close to the GPS antenna pad, is provided to customer for soldering the Microwave coaxial cable's outer conductor with the module's GND. The location of the GPS Antenna Connector and GPS antenna pad can be found in the following figure.

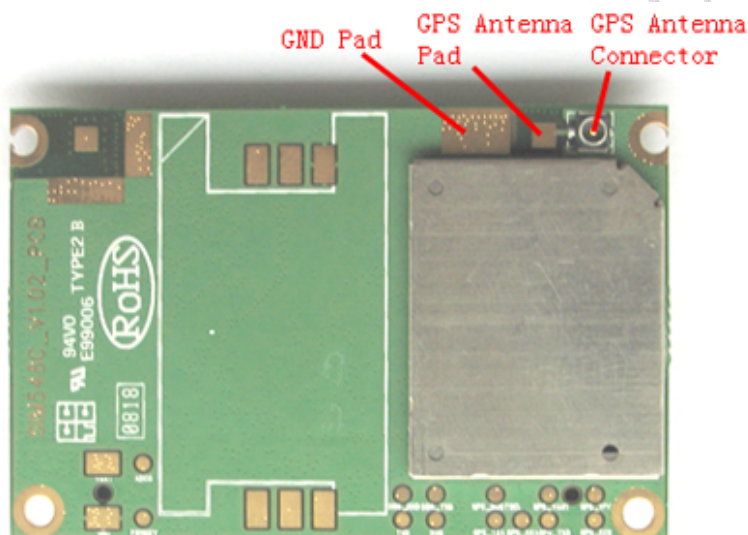

Figure 38: RF connector

5.2.2 GPS Antenna Choice Consideration

To obtain excellent GPS reception performance, a good antenna will always be required. The antenna is the most critical item for successful GPS reception in a weak signal environment. Proper choice and placement of the antenna will ensure that satellites at all elevations can be seen, and therefore, accurate fix measurements are obtained. Most customers contract with antenna design houses to properly measure the radiation pattern of the final mounted configuration in a plastic housing with associated components near the antenna. Linear antennas are becoming more popular, and the gain is reasonable, since a smaller ground plane can be used. Chose a linear

SIM548C Hardware Design

antenna with a reasonably uniform hemispherical gain pattern of $>-4\text{dBi}$. Use of an antenna with lower gain than this will give less than desirable results. Please note that a RHCP antenna with a gain of -3dBic , equates to a linear polarized antenna of -0dBi . Proper ground plane sizing is a critical consideration for small GPS antennas. Proper placement of the GPS antenna should always be the FIRST consideration in integrating the GPS Module.

If the customer's design will allow for a ceramic RHCP patch antenna with an appropriately sized ground plane, and the patch is normally oriented towards the sky, then that particular solution usually works the best. Please note that if the patch antenna ground plane is less than $60\times 60\text{mm}$, then compromises to the beam width and gain pattern could result. Usually the gain becomes very directional, and loses several dB of performance. Since results can vary, measuring the antenna radiation pattern in the final housing in an appropriate anechoic chamber will be required.

Some customers do not have the size availability to implement a patch antenna approach. In that instance, use of a Linear Polarized (LP) antenna is the next best alternative. There are new ceramic LP antennas on the market that exhibit reasonable gain characteristics once properly mounted in the housing, and when mated to an appropriate sized ground. That is the key point to consider here. "When mated to an appropriate sized ground".

Usually, the ground plane requirements are smaller for a LP antenna when compared to a patch, but once again, proper testing in an anechoic chamber is a mandatory requirement. These ceramic elements will need to be located near the end of the ground plane, and will require several mm of clearance between the closest component.

It is important to note that use of a LP antenna will result in a minimum of 3dB of gain loss when compared to a RHCP antenna at a defined elevation. This is due to the right hand gain rule of antenna propagation.

Use of PIFA antenna is another LP possibility, but the PIFA usually exhibits a considerable amount of gain nulls, or "holes" in the radiation pattern. This will be undesirable for obtaining a low circular error probability (CEP), since the antenna may not allow the receiver to capture the desired satellite at the ideal orientation due to these noted gain nulls.

Once again, careful testing in an appropriate anechoic chamber is required.

If the customer's design is for automotive applications, then an active antenna can be used and located on top of the car in order for guarantee the best signal quality.

Here are two GPS antenna manufacturers be recommended, you can visit their websites for details, <http://www.inpaq.com.tw> and <http://www.passivecomponent.com>. But the GPS antenna choice should base on the designing product and other conditions.

For detailed Antenna designing consideration, please refer to related antenna vendor's design recommendation. The antenna vendor will offer further technical support and tune their antenna characteristic to achieve successful GPS reception performance depends on the customer's design.

6 Electrical, reliability and radio characteristics

6.1 Absolute maximum ratings

Absolute maximum rating for power supply and voltage on digital and analog pins of SIM548C are listed in table 33 and table 34.

Table 33: Absolute maximum ratings (GSM part)

Parameter	Min	Max	Unit
Peak current of power supply	0	3.0	A
RMS current of power supply (during one TDMA- frame)	0	0.7	A
Voltage at digital pins	-0.3	3.3	V
Voltage at analog pins	-0.3	3.0	V
Voltage at digit/analog pins in POWER DOWN mode	-0.25	0.25	V

Table 34: Absolute maximum ratings (GPS part)

Parameter	Min	Max	Unit
Voltage at GPS_VCC	-0.3	5	V
Current at GPS_VCC_RF		25	mA

6.2 Operating temperatures

The operating temperature is listed in table35:

Table 35: Operating temperature

Parameter	Min	Typ	Max	Unit
Ambient temperature	-30	25	80	°C
Restricted operation*	-40 to -30		80 to 85	°C
Storage temperature	-45		+90	°C

* The module does work, but deviations from the GSM specification may occur, For example, the frequency error or the phase error will be large.

6.3 Power supply rating

Table 36: Power supply rating (GSM part)

Parameter	Description	Conditions	Min	Typ	Max	Unit	
VBAT	Supply voltage	Voltage must stay within the min/max values, including voltage drop, ripple, and spikes.	3.4	4.0	4.5	V	
	Voltage drop during transmit burst	Normal condition, power control level for Pout max			400	mV	
	Voltage ripple	Normal condition, power control level for Pout max @ f<200kHz @ f>200kHz			50 2	mV	
IVBAT	Average supply current)	POWER DOWN mode		35		uA	
		SLEEP mode (BS-PA-MFRMS=5)		2.5		mA	
		IDLE mode (Not connect console) EGSM 900 DCS 1800/ PCS 1900			23 23		mA
			IDLE mode (connect console) EGSM 900 DCS 1800/ PCS 1900			33 33	mA

SIM548C Hardware Design

		TALK mode				
		EGSM 900		260		mA
		DCS 1800/ PCS 1900		200		
		DATA mode, GPRS(3 Rx,2Tx)				
		EGSM 900		470		mA
		DCS 1800/ PCS 1900		340		
		DATA mode, GPRS(4 Rx,1Tx)				
		EGSM 900		275		mA
		DCS 1800/ PCS 1900		220		
Peak supply current (during transmission slot every 4.6ms)	Power control level			2	3.1	A

Table 37: Power supply rating (GPS part)

Parameter	Description	Conditions	Min	Typ	Max	Unit
GPS_VCC	Supply voltage		3.0	3.3	5	V
IGPS_VCC	Average supply current	Continuous mode (with antenna feeding on GPS_VCC_RF)		65	110	mA

Note: Basing on current standard GSW3 soft version, the power saving mode of GPS part is not available, that results 65 mA IGPS_VCC remained while the GPS receiver is running in normal mode.

6.4 Current consumption

6.4.1 The current consumption of the GSM part.

Table 38: Current consumption (GSM part)

Voice Call	
EGSM 900/EGSM 850	@power level #5 <350mA, Typical 260mA @power level #10, Typical 130mA @power level #19, Typical 86mA

SIM548C Hardware Design

DCS 1800/ PCS 1900	@power level #0 <300mA, Typical 200mA @power level #10, Typical 87mA @power level #15, Typical 80mA
GPRS Data	
DATA mode, GPRS (1 Rx,1 Tx)CLASS 8	
EGSM 900/ EGSM 850	@power level #5 <350mA, Typical 260mA @power level #10, Typical 125mA @power level #19, Typical 84mA
DCS 1800/ PCS 1900	@power level #0 <300mA, Typical 200mA @power level #10, Typical 83mA @power level #15, Typical 76mA
DATA mode, GPRS (3 Rx, 2 Tx)CLASS 10	
EGSM 900/EGSM 850	@power level #5 <550mA, Typical 470mA @power level #10, Typical 225mA @power level #19, Typical 142mA
DCS 1800/ PCS 1900	@power level #0 <450mA, Typical 340mA @power level #10, Typical 140mA @power level #15, Typical 127mA
DATA mode, GPRS (4 Rx,1 Tx)CLASS 8	
EGSM 900/EGSM 850	@power level #5 <350mA, Typical 270mA @power level #10, Typical 160mA @power level #19, Typical 120mA
DCS 1800/ PCS 1900	@power level #0 <300mA, Typical 220mA @power level #10, Typical 120mA @power level #15, Typical 113mA

Class 10 is default set when the module work at data translation mode, the module can also work at class 8 set by AT command.

6.4.2 The current consumption of the GPS part

To save more current consumption, we suggest the user to design their system in one of the two modes: 1. Power Down mode; 2.Push-To-Fix mode

6.4.2.1 Power down Mode

The circuit of this mode is shown in the figure:

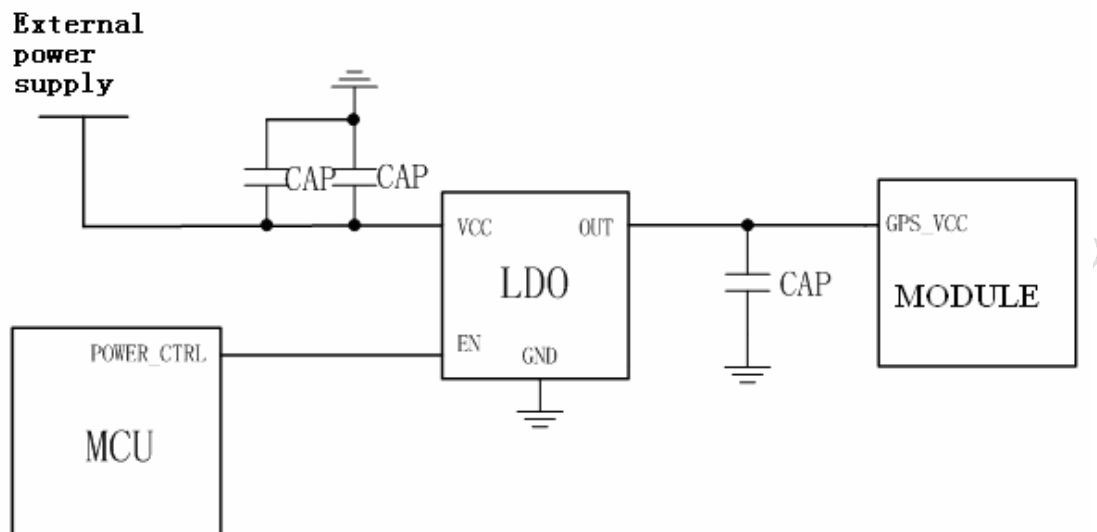

Figure 39: Power Down mode

When the user wants to save more current consumption of the GPS part, he can pull down the POWER_CTRL of the MCU to stop the LDO outputting. And this operation will cut off the power of the GPS part. *Note that the GPS_VRTC must be kept on.*

6.4.2.2 Push-To-Fix mode

The circuit of this mode is shown in figure 40.

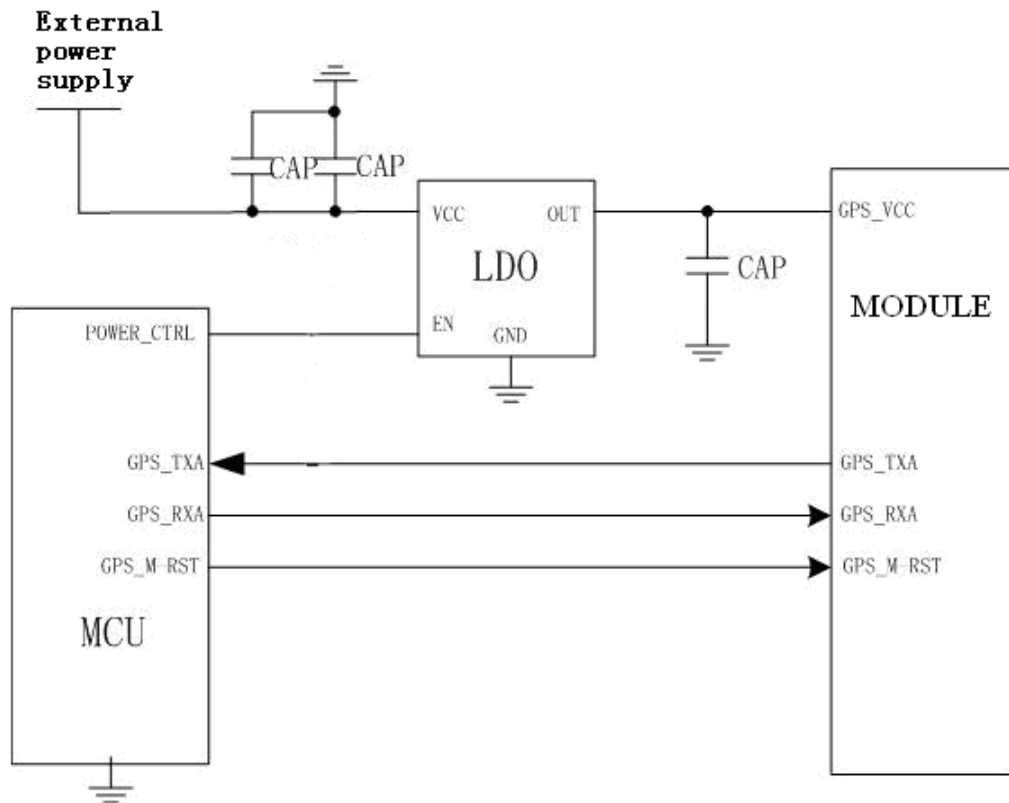

Figure 40: Push-To-Fix mode

The user can also save power by sending the “Push-To-Fix” command to the GPS part of the module.

The Push-to-Fix mode puts the receiver into a background duty cycle mode that provides a periodic refresh of position, GPS time, ephemeris, and RTC calibration every 10 seconds to 2 hours. Typical PTF operation is illustrated in Figure 39.

The PTF period is 30 minutes by default but can be anywhere between 10 seconds and 2 hours. When the PTF mode is enabled, upon power on or a new PTF cycle, the receiver will stay on full power until the good navigation solution is computed. The stand-by state will follow for the remainder of the period. If it took 36 seconds to fix position and refresh ephemeris on the default period of 30 minutes, the receiver will sleep for the 29 minutes and 24 seconds. When the application needs a position report, it can toggle the GPS_M-RST pin to wake up the receiver. When the receiver wakes up, it can produce a valid position in the normal hot-start time.

Power consumption in the PTF mode

Again, a typical setting of 1800 seconds PTF interval is considered.

Assuming it takes 8 seconds to compute a good position since the start of a cycle, the average current and power consumption of each typical cycle is:

$$I_{avg} = (65 \text{ mA} * 8160 \text{ ms} + 1 \text{ mA} * 1791840 \text{ ms}) / 1800 \text{ seconds} = 1.290 \text{ mA}$$

$$P_{avg} = 3.3 \text{ V} * 1.290 \text{ mA} = 4.257 \text{ mW}$$

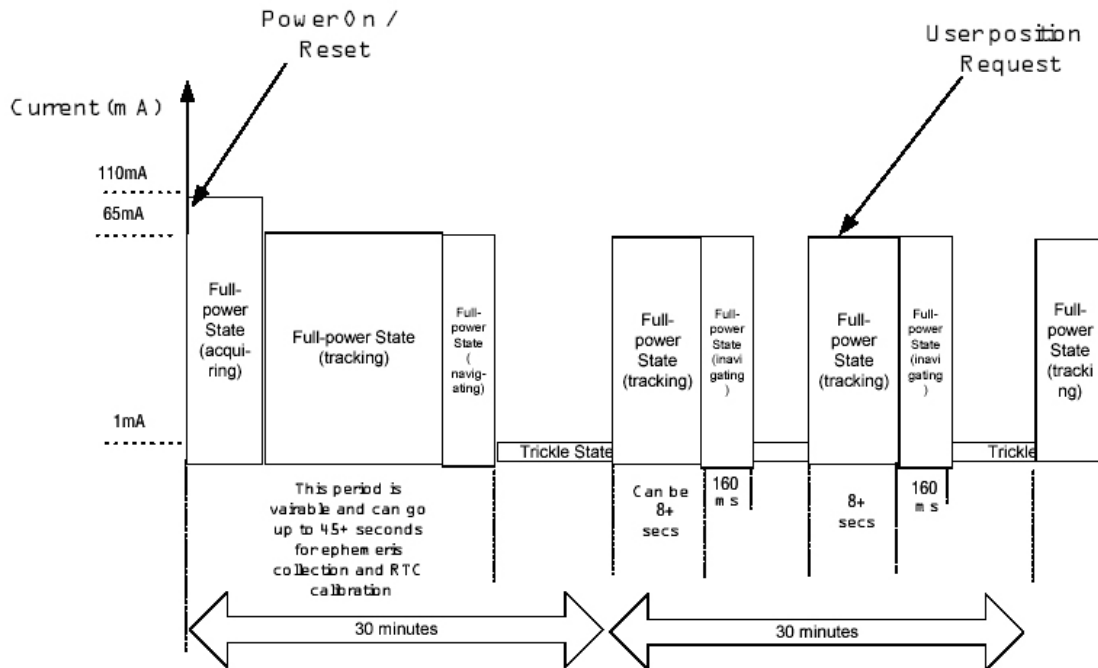

Figure 41: Power consumption in the PTF mode

Note:

1. When the user wants to use Power Down mode or Push-To-Fix mode, the RTC battery must be 2.5V+. If the RTC battery level is lower than 2.5V, the module will not go into PTF mode.
2. Push-To-Fix mode is only available in protocol of :SiRF binary, please refer to the document [2].

6.5 Electrostatic discharge

The GSM engine is not protected against Electrostatic Discharge (ESD) in general. Therefore, it is subject to ESD handling precautions that typically apply to ESD sensitive components. Proper ESD handling and packaging procedures must be applied throughout the processing, handling and operation of any application using a SIM548C module.

The measured values of SIM548C are shown as the following table:

Table 39: The ESD endure statue measured table (Temperature: 25°C, Humidity: 45%)

Part	Contact discharge	Air discharge
VBAT,GND	±6KV	±10KV
DTR, RXD, TXD, RTS, DISP_DATA, DISP_CLK	±4KV	±10KV
Antenna port	±4KV	±8KV
Other port	±4KV	±8KV

7 Mechanics

This chapter describes the mechanical dimensions of SIM548C.

7.1 Mechanical dimensions

Following shows the Mechanical dimensions of SIM548C.

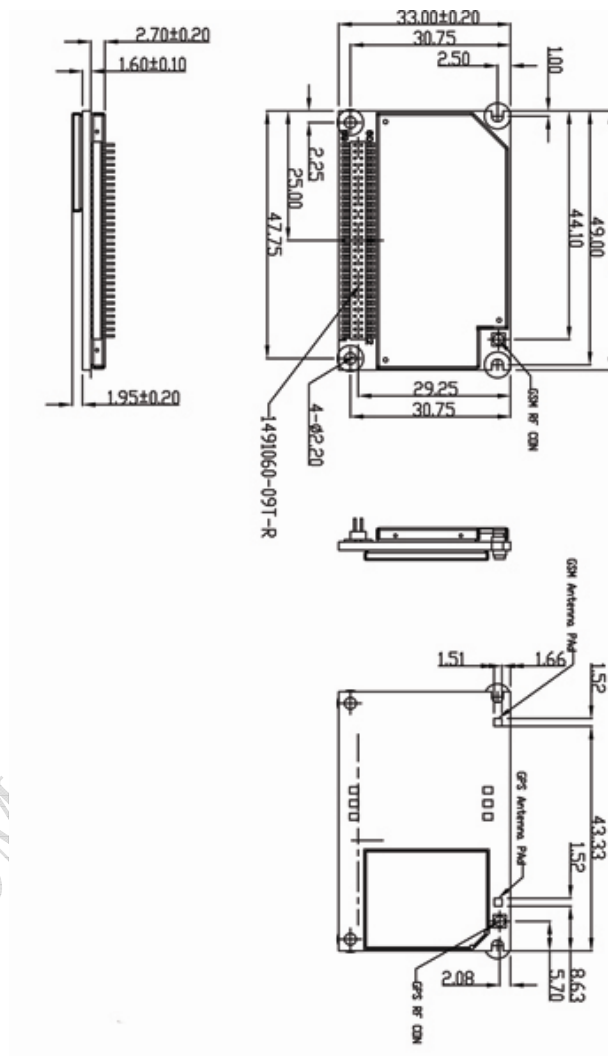

Figure 42: Mechanical dimensions of module (Unit: mm)

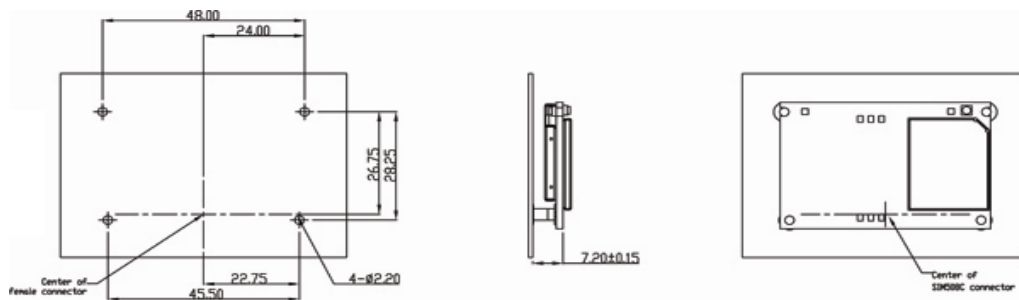

Figure 43: Mount the module (Unit: mm)

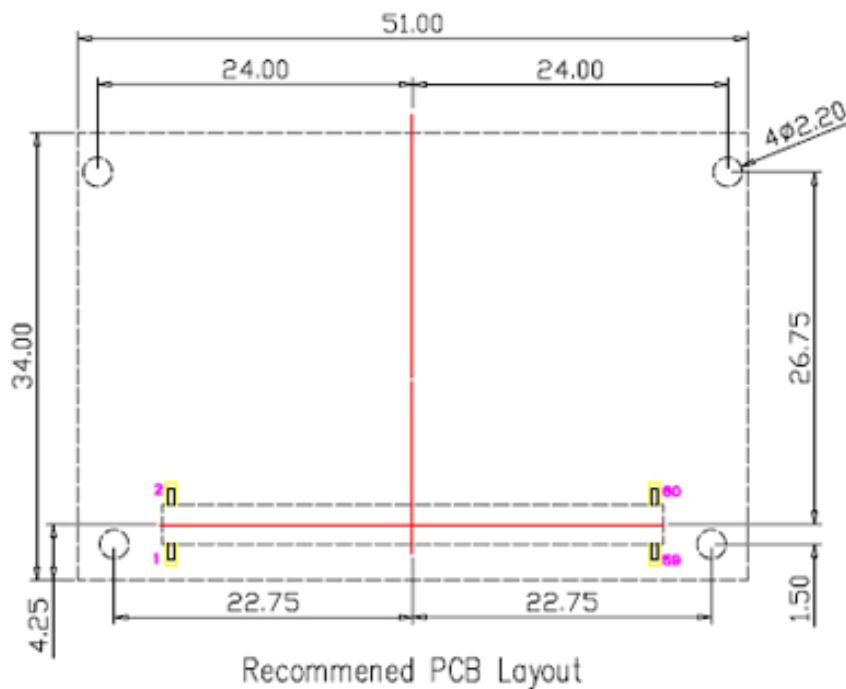

Figure 44: Mechanical dimensions of module PCB decal (Unit: mm)

7.2 Mounting the module onto the application platform

Use the connector ASTRON1491060-09T-R and four pads to fix the SIM548C onto customer platform.

7.3 Board-to-board connector

We recommend ASTRON Company's 1491060-09T-R and 1590060-09T-R as the board-to-board connector. These high density SMT connectors are designed for parallel PCB-to-PCB applications.

7.3.1 Mechanical dimensions of the ASTRON 1590060-09T-R

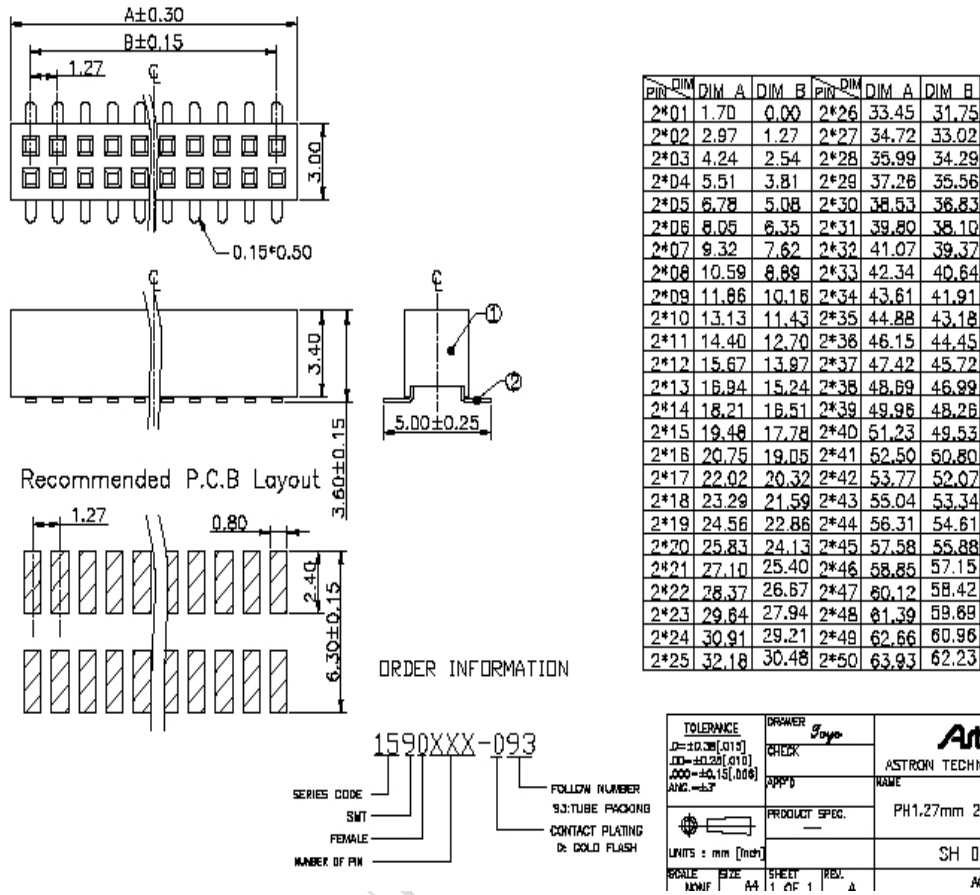

Figure 45: ASTRON1590060-09T-R Board to Board connector

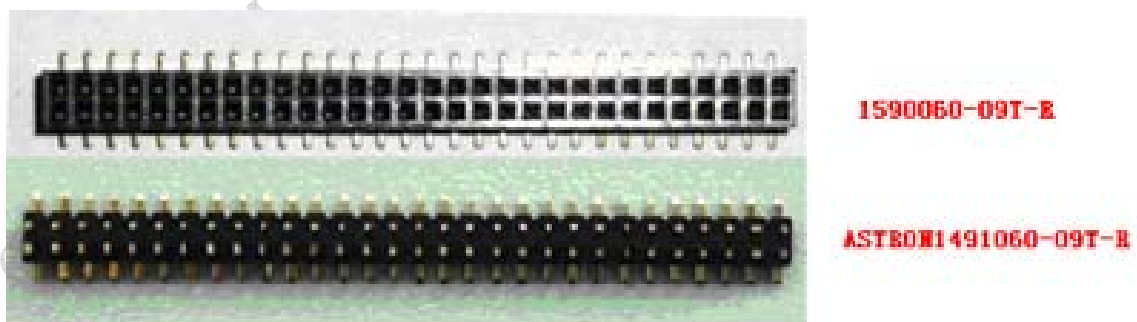

Figure 46: ASTRON Board to Board connector physical photo

Note : The connector ASTRON ASTRON1491060-09T-R is used in pin side (548C module) and 1590060-09T-R is used in socket side (user side).

7.3.2 Adapter cabling

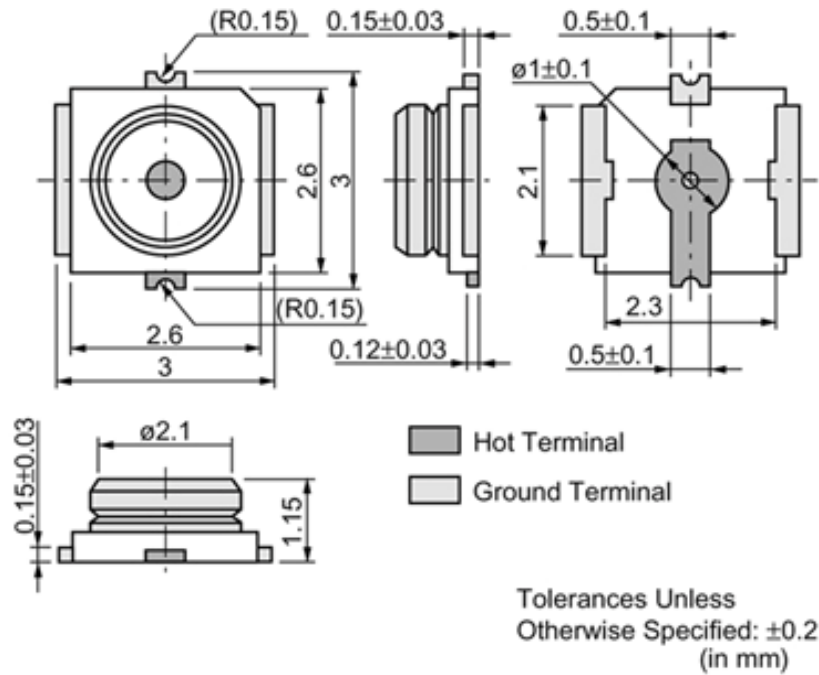

Figure 47: MM9329-2700B

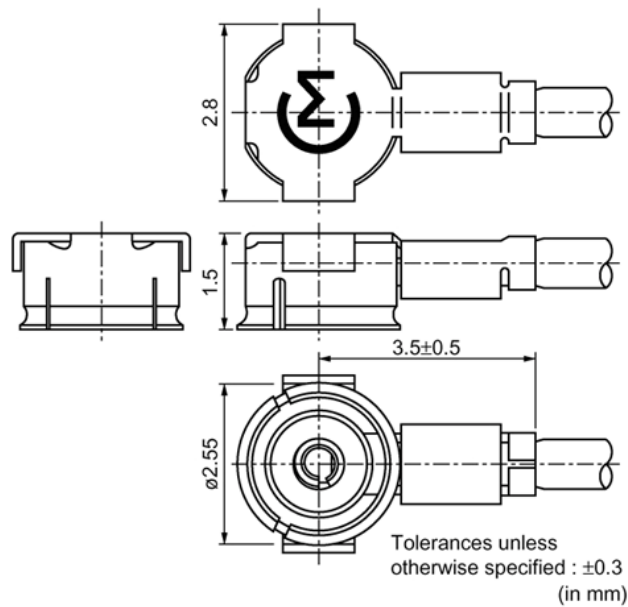

Figure 48: RF connector MXTK

For more information about the connector, please visit <http://www.murata.com/>

APPENDIX A: PIN assignment of board-to-board connector

Table 40: Pin assignment

PIN NO.	PIN NAME	I/O		PIN NO.	PIN NAME	I/O
1	GND			2	VBAT	I
3	GND			4	VBAT	I
5	GND			6	VBAT	I
7	GND			8	VBAT	I
9	ADC0	I		10	VCHG	I
11	VRTC	I/O		12	VCHG	I
13	PWRKEY	I		14	TEMP_BAT	I
15	SIM_PRESENCE	I		16	NETLIGHT	O
17	SIM_VDD	O		18	BUZZER	O
19	SIM_RST	O		20	STATUS	O
21	SIM_DATA	I/O		22	GPIO1	I/O
23	SIM_CLK	O		24	DISP_CS	O
25	DCD	O		26	DISP_CLK	O
27	DTR	I		28	DISP_DATA	I/O
29	RXD	I		30	DISP_D/C	O
31	TXD	O		32	DISP_RST	O
33	RTS	I		34	GPIO0	I/O
35	CTS	O		36	DBG_RXD	I
37	RI	O		38	DBG_TXD	O
39	AGND			40	AGND	
41	SPK1P	O		42	MIC1P	I
43	SPK1N	O		44	MIC1N	I
45	SPK2P	O		46	MIC2P	I
47	SPK2N	O		48	MIC2N	I
49	GPS_M-RST	I		50	GPS_BOOTSEL	I
51	GPS_TXA	O		52	GPS_TIMEMAR K	O
53	GPS_RXA	I		54	GPS_WAKEUP	I
55	GPS_TXB	O		56	GPS_VCC_RF	O
57	GPS_RXB	I		58	GPS_VANT	I
59	GPS_VRTC	I		60	GPS_VCC	I

SIM548C Hardware Design

The following figure is a top-view of SIM548C module. With the indication of Pin 1, 2, 59 and 60.

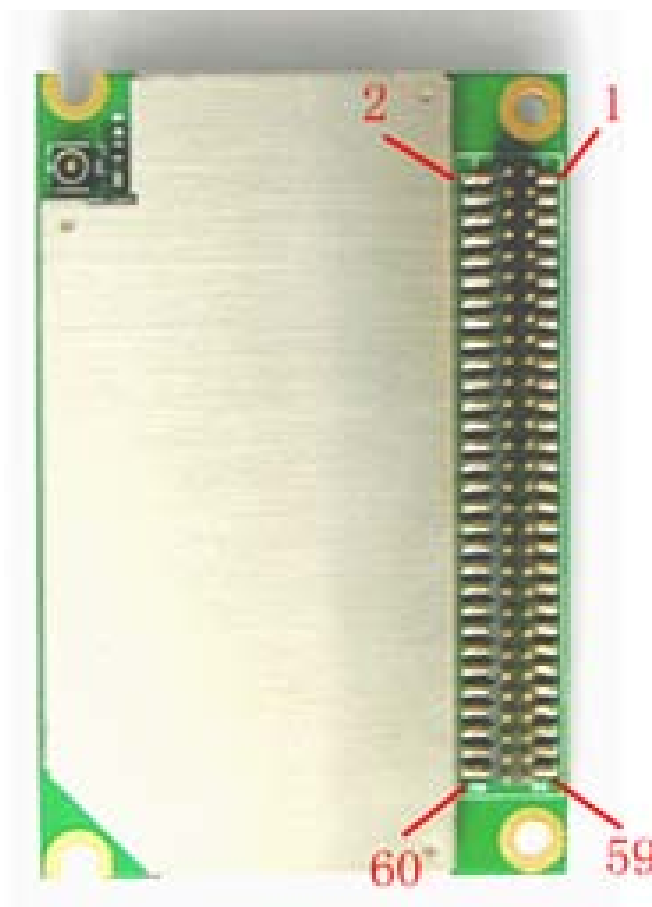

Figure 49: physical SIM548C

APPENDIX B: Reference Circuit with external MCU (GPS standalone application)

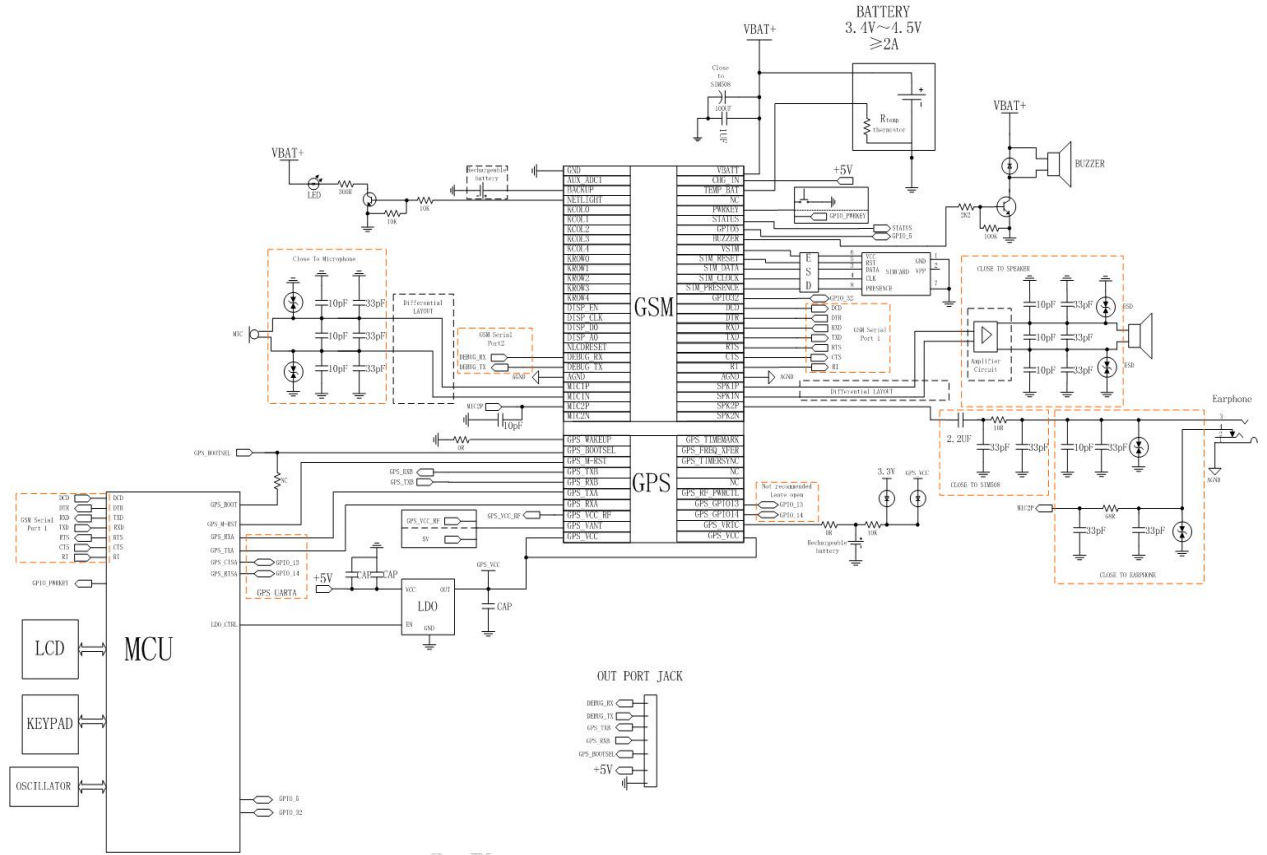

Figure 50: Reference Circuit with external MCU (standalone application for example)

APPENDIX C: Reference Diagram with external MCU (AGPS application)

The next Figure shows the connection for AGPS application ,DISP_DATA pin is used for TX and DISP_D/C for RX. For details please refer to *AGPS application note* document.

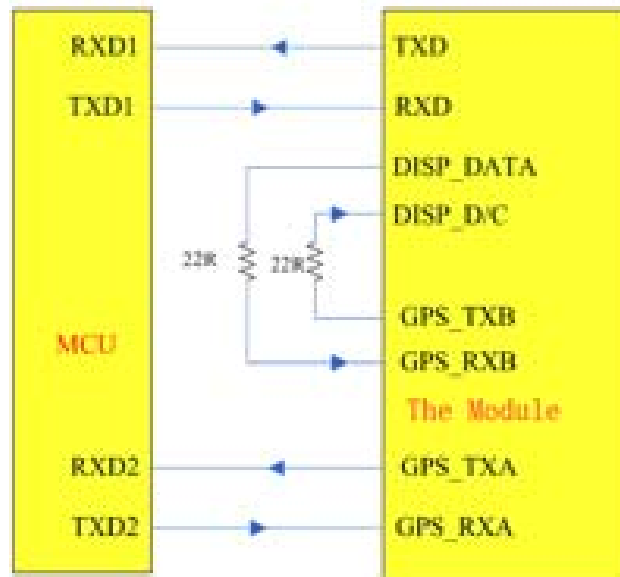

Figure 51: AGPS connection

Contact us:

Shanghai SIMCom Wireless Solutions Ltd.

Add: SIM Technology Building, No. 700, Yishan Road, Shanghai, P. R. China 200233

Tel: +86 21 5427 8900

Fax: +86 21 5427 6035

URL: www.sim.com/wm/

SIMCOM CONFIDENTIAL FILE